



Power control for wind turbines in weak grids: Concepts development

Bindner, H.

Publication date:
1999

Document Version
Publisher's PDF, also known as Version of record

[Link back to DTU Orbit](#)

Citation (APA):
Bindner, H. (1999). *Power control for wind turbines in weak grids: Concepts development*. Denmark. Forskningscenter Risoe. Risoe-R, No. 1118(EN)

General rights

Copyright and moral rights for the publications made accessible in the public portal are retained by the authors and/or other copyright owners and it is a condition of accessing publications that users recognise and abide by the legal requirements associated with these rights.

- Users may download and print one copy of any publication from the public portal for the purpose of private study or research.
- You may not further distribute the material or use it for any profit-making activity or commercial gain
- You may freely distribute the URL identifying the publication in the public portal

If you believe that this document breaches copyright please contact us providing details, and we will remove access to the work immediately and investigate your claim.

Power Control for Wind Turbines in Weak Grids: Concepts Development

Henrik Bindner

Abstract Presently, high wind potentials in remote areas may not be utilized for electricity production due to limited grid transmission capacity and/or difficulties in matching the electricity production with the demand. The overall project objective is to help overcome these bottlenecks, i.e. to identify and analyze methods and technologies for making it viable to utilize more of the wind potential in remote areas. The suggestion is to develop a power control concept for wind turbines which will even out the power fluctuations and make it possible to increase the wind energy penetration. The main options are to combine wind power with a pumped hydro power storage or with an AC/DC converter and battery storage. The AC/DC converter can either be an “add-on” type or it can be designed as an integrated part of a variable speed wind turbine. The idea is that combining wind power with the power control concept will make wind power more firm and possible to connect to weaker grids. So, when the concept is matured, the expectation is that for certain wind power installations, the cost of the power control is paid back as added wind power capacity value and saved grid reinforcement costs.

Different systems for controlling the power output from a wind farm connected to a weak grid have been investigated. The investigation includes development of different control strategies, use of different storage types, development of a framework for comparing different options and tools needed as part of the framework.

The main issues in the assessment of the power control concept are the storage capacity and power rating compared to the installed wind power capacity. The model SimStore has been developed to assess that.

The economic investigations have shown that for small systems where only small amounts of wind energy would otherwise have been dumped add-on PQ-controllers with battery storage can be the least cost option compared to grid reinforcement and dumping of energy. For larger systems pumped storage is attractive and worth considering, but for large systems the least cost option is grid reinforcement.

Power control technology in combination with wind farms can also contribute to the development of remote regions because such technology will improve the infrastructure of the region and therefore increasing the conditions for local trade and industry

ISBN 87-550-2549-3
ISBN 87-550-2550-1(Internet)
ISSN 0106-2840

Information Service Department, Risø, 1999

Contents

1	Introduction	5
1.1	Outline of the project	5
1.2	Definition of weak grid	6
1.3	Basic power control idea	6
1.4	Outline of report	6
2	Basic Problems with Wind Turbines in Weak Grids	7
2.1	Voltage level	7
2.2	Voltage fluctuations	8
3	Basic Power Control Idea	8
4	Control Strategies	10
4.1	Voltage peak limitation	10
4.2	Voltage control	10
4.3	Power Fluctuations	11
4.4	Firm power	11
4.5	Tariff control	12
5	Power Control Concepts	12
5.1	Pumped storage concept	12
5.2	Integrated storage concept	15
5.3	Add-on storage concept	17
5.4	Other configurations	19
6	Power Control Assessment Framework	19
7	Simulation Tools	21
7.1	Load flow	21
7.2	WINSYS	21
7.3	INPARK	22
7.4	SimStore	23
8	Description of SimStore	23
8.1	Overall framework	23
8.2	Load model	24
8.3	Wind turbine and wind speed model	24
8.4	Storage models	25
	Pumped storage model	25
	Battery storage model	26
8.5	Control system	28
9	Simulation Results	29
10	Performance Indications of PQ-controllers	31
10.1	Technical performance	31
10.2	Economic performance	35
11	Conclusions	39
	References	40

1 Introduction

Presently, high wind potentials in remote areas may not be utilized for electricity production due to limited grid transmission capacity and/or difficulties in matching the electricity production with the demand. The overall project objective is to help overcome these bottlenecks, i.e. to identify and analyze methods and technologies for making it viable to utilize more of the wind potential in remote areas. The suggestion is to develop a power control concept for wind turbines which will even out the power fluctuations and make it possible to increase the wind energy penetration. The main options are to combine wind power with a pumped hydro power storage or with an AC/DC converter and battery storage. The AC/DC converter can either be an “add-on” type or it can be designed as an integrated part of a variable speed wind turbine. The idea is that combining wind power with the power control concept will make wind power more firm and possible to connect to weaker grids. So, when the concept is matured, the expectation is that for certain wind power installations, the cost of the power control is paid back as added wind power capacity value and saved grid reinforcement costs.

1.1 Outline of the project

The project consists of four work packages:

- Develop concept: General development of the power control concept in combination with wind turbines
- Test prototype: Testing of a PQ-controller with a battery storage in combination with a wind turbine
- Madeira case study: Feasibility study of the applicability of the power control concept in the Madeira power system.
- County Donegal case study: Feasibility study of the applicability of the power control concept in County Donegal.

In the first task is the general power control concept developed and investigated. Various options are studied in both technical and economic terms. The options include pumped storage and batteries for storing wind energy and different control strategies. In order to carry out the investigations models have been developed that can assess the technical and economic performance. Included in this task is a market assessment study.

Development and testing of an actual prototype of the ‘add-on’ type of a power controller is done as the second task. Both the hardware and the software for controlling the controller has been developed. Initial test of the system has also been carried out.

The third and fourth tasks are two case studies. The first case is on Madeira. Madeira is a island with a local power supply system. The system is characterised by diesel generation as the primary generation type, a rather large amount of run-of-the-river type hydro plants and some wind farms. The wind resources are favourable and the conventional generation cost are rather high. The issues involved include utilisation of the wind energy, steady state and dynamic behaviour of the voltage in combination with a power control concept. The second case study is in County Donegal in Ireland. The situation there is that the grid has a very limited capacity and there are some very favourable wind resources.

There are also some good sites for pump storage. The main investigation here is the combination of wind energy and pumped storage.

The main results of the project is described in the project summary report 'Power Control for Wind Turbines in Weak Grids: project Summary', Risø-R-1117(EN), Henrik Bindner (Ed.), Roskilde 1999.

1.2 Definition of weak grid

The term 'weak grid' is used in many connections both with and without the inclusion of wind energy. It is used without any rigour definition usually just taken to mean the voltage level is not as constant as in a 'stiff grid'. Put this way the definition of a weak grid is a grid where it is necessary to take voltage level and fluctuations into account because there is a probability that the values might exceed the requirements in the standards when load and production cases are considered. In other words, the grid impedance is significant and has to be taken into account in order to have valid conclusions.

Weak grids are usually found in more remote places where the feeders are long and operated at a medium voltage level. The grids in these places are usually designed for relatively small loads. When the design load is exceeded the voltage level will be below the allowed minimum and/or the thermal capacity of the grid will be exceeded. One of the consequences of this is that development in the region with this weak feeder is limited due to the limitation in the maximum power that is available for industry etc.

The problem with weak grids in connection with wind energy is the opposite. Due to the impedance of the grid the amount of wind energy that can be absorbed by the grid at the point of connection is limited because of the upper voltage level limit. So in connection with wind energy a weak grid is a power supply system where the amount of wind energy that can be absorbed is limited by the grid capacity and not e.g. by operating limits of the conventional generation.

1.3 Basic power control idea

The basic power control idea investigated in the current project is to buffer wind energy in situations where the grid voltage would otherwise exceed the limit and then release at a later time when the voltage of the grid is lower.

The main idea is to combine a wind farm with an energy storage and a control system and then be able to connect a larger amount of wind capacity without exceeding the voltage limits and without grid re-enforcement and still have a profitable wind energy system.

1.4 Outline of report

The report initially presents the basic problem with wind turbines in weak grids in some details. It then continues with a detailed presentation of the power control concept and various ways of implementing such concepts. This includes discussions on different storage technologies and control strategies. Then a framework for assessing power control options (in both technical and economic

terms) as a mean of integrating more wind energy is presented. A simulation model for assessing the voltage level, amount of wind energy and storage size has been developed as part of the project and it is described in some details. The report ends with a short indication of the size, performance and cost associated with power control concepts as a solution to wind energy integration in weak grids.

2 Basic Problems with Wind Turbines in Weak Grids

2.1 Voltage level

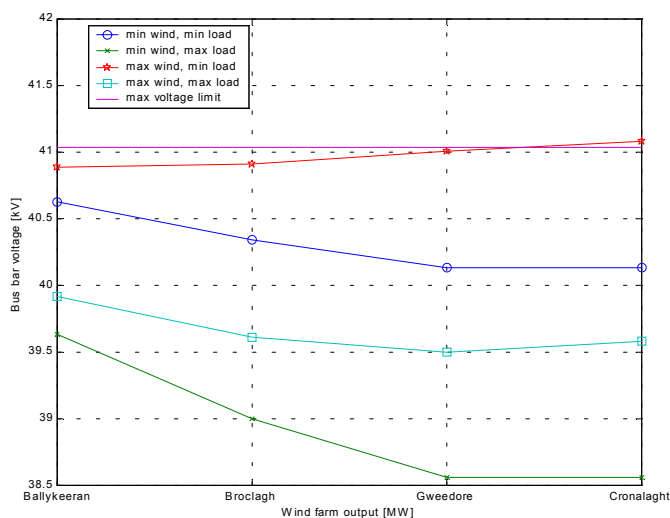

Figure 1 Example of voltage profile for feeder with and without wind power

The main problem with wind energy in weak grids is the quasi-static voltage level. In a grid without wind turbines connected the main concern by the utility is the minimum voltage level at the far end of the feeder when the consumer load is at its maximum. So the normal voltage profile for a feeder without wind energy is that the highest voltage is at the bus bar at the substation and that it drops to reach the minimum at the far end. The settings of the transformers by the utility are usually so, that the voltage at the consumer closest to the transformer will experience a voltage, that is close to the maximum value especially when the load is low and that the voltage is close to the minimum value at the far end when the load is high. This operation ensures that the capacity of the feeder is utilised to its maximum.

When wind turbines are connected to the same feeder as consumers which often will be the case in sparsely populated areas the voltage profile of the feeder will be much different from the no wind case. Due to the power production at the wind turbine the voltage level can and in most cases will be higher than in the no wind case. As is seen on the figure the voltage level can exceed the maximum allowed when the consumer load is low and the power output from the wind turbines is high. This is what limits the capacity of the feeder. The voltage

profile of the feeder depends on the line impedance, the point of connection of the wind turbines and on the wind power production and the consumer load.

For a simple single load case the voltage rise over the grid impedance can be approximated with

$$\Delta U \cong (R * P + X * Q) / U$$

using generator sign convention. This formula indicates some of the possible solutions to the problem with absorption of wind power in weak grids. The main options are either a reduction of the active power or an increase of the reactive power consumption or a reduction of the line impedance.

2.2 Voltage fluctuations

Another possible problem with wind turbines in weak grids are the possible voltage fluctuations as a result of the power fluctuations that comes from the turbulence in the wind and from starts and stops of the wind turbines. As the grids becomes weaker the voltage fluctuations increase given cause to what is termed as flicker. Flicker is visual fluctuations in the light intensity as a result of voltage fluctuations. The human eye is especially sensitive to these fluctuations if they are in the frequency range of 1-10 Hertz. Flicker and flicker levels are defined in IEC1000-3-7, [1].

During normal operation the wind turbulence causes power fluctuations mainly in the frequency range of 1-2 Hertz due to rotational sampling of the turbulence by the blades. This together with the tower shadow and wind shear are the main contributors to the flicker produced by the wind turbine during normal operation. The other main contribution to the flicker emission is the cut-in of the wind turbine. During cut-in the generator is connected to the grid via a soft starter. The soft starter limits the current but even with a soft starter the current during cut-in can be very high due to the limited time available for cut-in. Especially the magnetisation current at cut-in contributes to the flicker emission from a wind turbine.

3 Basic Power Control Idea

The main idea is to increase the amount of wind energy that can be absorbed by the grid at a certain point with minimum extra cost.

There exist several options that can be implemented in order to obtain a larger wind energy contribution. These options include:

- Grid reinforcement
- Voltage dependent disconnection of wind turbines
- Voltage dependent wind power production
- Inclusion of energy buffer (storage)
- Determination of actual voltage distribution instead of worst case and evaluation if real conditions will be a problem

Grid reinforcement increases the capacity of the grid by increasing the cross section of the cables. This is usually done by erecting a new line parallel to the

existing line for some part of the distance. Because of the increased cross section the impedance of the line is reduced and therefore the voltage variations as a result of power variations are reduced. Grid reinforcement increases both the amount of wind energy that can be connected to the feeder and the maximum consumer load of the feeder. Since the line impedance is reduced the losses of the feeder are also reduced. Grid reinforcement can be very costly and sometimes impossible due to planning restrictions.

Since grid reinforcement can be very costly or impossible other options are interesting. The most simple alternative is to stop some of the wind turbines when the voltage level is in danger of being exceeded. This can e.g. be done by the wind turbine controller monitoring the voltage level at the low voltage side of the connection point. At a certain level the wind turbine is cut off and it is then cut in again when the voltage level is below a certain limit. The limits can be precalculated and depends on transformer settings, line impedance and other loads of the feeder. This is a simple and crude way of ensuring that the voltage limits will not be exceeded. It can be implemented at practically no cost but not all the potentially available wind energy is utilised.

A method that is slightly more advanced is to continuously control the power output of the wind turbine in such a way that the voltage limit is not exceeded. This can be done on a wind farm level with the voltage measured at the point of common connection. The way of controlling the power output requires that the wind turbine is capable of controlling the output (pitch or variable speed controlled) and a bit more sophisticated measuring and control equipment, but the amount of wind energy that is dumped is reduced compared to the option of switching off complete wind turbines.

The basic power control idea in the current context of this project is based on the combination on wind turbines and some kind of energy storage. The storage is used to buffer the wind energy that cannot be feed to the grid at the point of connection without violating the voltage limits. Usually the current limit of the grid will not be critical. The energy in the storage can then be fed back to the grid at a later time when the voltage level is lower.

The situations where the voltage level will be high will occur when the consumer load of the grid is low and the wind power production is high. If the voltage level will be critically high depends on the characteristics of the grid (e.g. impedance and voltage control), the minimum load of the consumers, the amount of installed wind power and the wind conditions.

The critical issues involved in the design of a power control system are the power and energy capacity, the control bandwidth as well as investment, installation and maintenance cost. The various types of power control systems have different characteristics giving different weights on capacity, investment and maintenance.

Different types of storage can be applied. During the project only pumped storage and batteries has been investigated. Other types of storage include flywheel, super conducting magnetic storage, compressed air and capacitors. These types of storage have not been investigated for several reasons among them cost, capacity and availability.

4 Control Strategies

Several different control strategies exist for a power controller with storage. The different control strategies place different weights on voltage and power fluctuations and therefore have different impact on the sizing of the storage capacity and of the power rating.

The two main types of control strategies are ones controlling the voltage at the point of common connection or another point in the grid and the ones controlling the power for smoothing or capacity increase.

4.1 Voltage peak limitation

The first control strategy is to limit the number of occurrences of voltage excursions above the upper voltage limit by absorbing the excess power in the storage.

Since the probability of overvoltage is higher at certain times of the day one possible control strategy is to start up e.g. a pumped storage plant at the beginning of such a period and then let it run pumping water up to the upper reservoir during that period at a certain power level that will ensure that overvoltages will only occur very seldom. The period could be 4-5 hours during the night. The stored energy could then be released during high load periods e.g. during the evening. The rating of the pumps and the capacity of the reservoir have to be sized to accommodate for the power and energy requirements but the control would be very simple. The size of the reservoir would have to be quite large since it would have to accommodate the large amount of energy that has to be absorbed during a relatively long period of time and since there is no feed back whether the voltage is high or not. The control of the system will be extremely simple since all it requires is a start signal and a stop signal. It will also involve only proven technology.

In order to reduce the required reservoir size measurement of the grid voltage can be included in the control of the system. Now the system will only start up if the voltage exceeds a certain level and it will shut down if the voltage is below a certain other value. Depending on the technology the limits for starting and stopping the plant can be close to the voltage limit or a bit away from the limit. So now storage capacity is only needed when the voltage is high. If the storage is large enough as well as the power rating this system can eliminate overvoltages.

In order to be able to estimate the required size some kind of simulation tool is needed that can take the stochastic nature of both the wind and the load into consideration.

4.2 Voltage control

Limiting the maximum voltage level is very important but sometime more accurate control is desired. This can include maintaining the voltage level and reduce flicker. When these features are implemented the total system, wind farm and power control plant, will be an active part of the power supply system.

Some of the reasons behind this can be a desire to improve the general power quality of the area and eliminate the impact of wind energy on the voltage.

When the control strategy is to maintain the voltage level and reduce flicker the power control plant has to be active all the time. The requirements to the size of the storage is increased since it now should be able to supply energy in large amounts during low voltage situations and also the requirements to handle fast variations are increased since flicker is in the range up to 15 Hz. The plant will also be able to supply and absorb reactive power.

Again simulation models are needed These will have to be able to estimate the size of both the power and the storage as well as the dynamic performance if flicker is to be eliminated.

4.3 Power Fluctuations

Instead of controlling the voltage at the point of connection another control parameter could be the output power from a wind farm. The objective can e.g. be to keep the output power as constant as possible. This will eliminate voltage fluctuations generated by the wind farm and therefore also flicker. Another benefit by this way of controlling the total system, wind farm and power controller, is that the impact on the other generating components is very limited and the stochastic nature of the wind power is reduced.

Since it will require a very large storage system to keep the output constant at all times it will be more realistic to let the output of the total system vary slowly with the mean wind energy production . This will still make the wind energy seem more firm since the variations are more slow and therefore more stable. It will also reduce the flicker since the fast variations in the output power from the wind farm are absorbed by the storage system.

The reactive power can be controlled in the same way. The only difference is that control of the reactive power does only require a very minimal storage capacity.

The requirements to the bandwidth of the power controller hardware are relatively high if all fluctuations causing flicker are to be eliminated. Modern power electronics will be able to obtain the required bandwidth.

4.4 Firm power

As for the previous strategy one of the objectives can be to supply firm power. Firm power is here understood to be power that can be scheduled. In connection with wind power and weak grids important aspects are the ability to inject power during high load periods thus reducing the requirements for conventional capacity and reducing the impact of voltage drop on the feeder during the same high load periods.

A firm power strategy will be an additional strategy since it on its own will not reduce the voltage level during high voltage periods.

In order to be able to inject power into the power system when it is required it is necessary that the storage has enough energy stored. It is clear that because

some of the capacity of the storage is already taken up by the need to be able to supply power when required either the storage capacity has to be increased if the same level of overvoltage probability is desired or there will be an increase in overvoltage probability.

4.5 Tariff control

Tariff control is like firm power control an additional control strategy. The idea is that the storage is filled during periods with a low tariff and the energy is released when the tariff is high. If there is a large difference between the low and high tariff additional money can be earned by the plant owner.

As for the firm power control strategy there is a probability that an overvoltage will occur when the storage is filled due to the transferring of energy from low tariff periods to high tariff periods either the storage has to be increased or the overvoltage probability will increase. Another aspect of the Tariff control strategy is that it has to be remembered that significant amounts of energy are lost in the conversion (20-30%).

5 Power Control Concepts

As described above there exist several control strategies for power controllers. When they are combined with different types of storage systems several different kinds of power control concepts exist. The main options studied in the current project concerns pumped storage and batteries combined with control strategies that are based on the natural strength of the two storage types.

5.1 Pumped storage concept

In a pumped storage power control system a system with two water reservoirs with a head difference is used as storage. Water is pumped from the lower head to the higher head when power has to be absorbed and it is released through a turbine when the grid can absorb the stored energy.

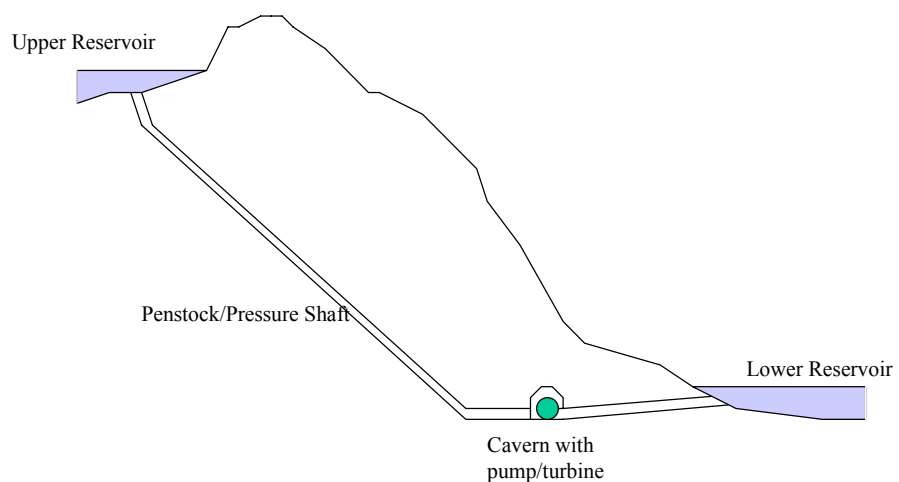

Figure 2 Principle layout of pumped storage plant

The principal components of the pumped storage system are (Figure 2)

- Upper reservoir
- Lower reservoir
- Pressure shaft (Penstock)
- Turbine/Pump house
- Turbine
- Pump
- Generator
- Motor
- Control system

The two reservoirs can be two lakes situated close to each other or it can be an artificial reservoir as the upper reservoir and natural lake as the lower or it can be an artificial reservoir as the upper reservoir with the sea acting as the other reservoir. In the last case the water being pumped and stored will of course be saltwater. The construction of the upper reservoir will then have to take that into account so that the salty water does not leak through the bottom of the reservoir and pollute the ground and the ground water with salt. It is also important the turbine, pump and pressure shaft are constructed to handle saltwater.

The difference in head between the two reservoirs determines together with the dimensions of the pressure shaft the power that is available. The capacity of the storage is determined by the change in head from full to empty, the area of the reservoir and difference in head between the two reservoirs.

The conversion from kinetic energy of the falling water to electrical energy takes place in the turbine/generator arrangement in the turbine/pump house. There exist different types of turbines with different features. In order to save investment it is desirable to use a turbine type that is good both as a turbine and as a pump.

As for the turbine/pump it is desirable to have only one generator/motor per turbine/pump. There are two basic choices for generator, synchronous and induction generators. For larger plant synchronous generators will be the natural choice since the plant will look very much like a conventional hydro plant with the same possibilities to participate in the voltage control of the grid. For small plants induction machines could be an alternative.

The control system implements the desired control strategy and manages changes in power flow direction and prevents components from being overloaded.

The bandwidth of the pumped storage plant is sufficient to eliminate the lower frequency fluctuations thus eliminating the over-voltage situations. It is not desirable to have the plant to eliminate flicker. This is for control reasons in order not to put too much load on the speed controller and voltage controller.

The start up time and the time it takes to reverse the power flow are rather long. The start up time is in the range of 1 minute and the power reversal time is in the range of 8-10 minutes.

The overall efficiency is approx. 75% taking losses in the motor/generator, turbine and the hydraulic part into account.

Pumped storage plants integrate very well with the conventional power system. This is due to the fact that it is build as a hydro plant with the exception that it can also pump water and therefore absorb energy. The possibilities for control of the power and the voltage are the same as for a hydro plant and it can therefore be treated in the same way.

Pumped storage systems will typically be rather large compared to systems with batteries or flywheels. This is due to the high cost of establishing the pressure shaft and the reservoir, both costs being relatively insensitive to the size of the plant. This means that it in order to decrease the specific investment the plants will be large. This can be seen in Table 1 where there is a clear tendency for lower cost at larger plant sizes.

Table 1 Specific cost of pumped storage systems plants, [Donegal Data].

Size generate/pump (kW)	650/900	11000/16000	7500/10000	8000/11000	6000/8000
Total Investment (ECU/kWout)	1825	851	706	566	832

Table 2 Break down of cost of pumped storage plants, [Donegal data].

Size generate/pump (kW)	650/900	11000/16000	7500/10000	8000/11000	6000/8000
Penstock (% of total)	42,1%	45,9%	37,4%	21,9%	13,6%
Civil Works (% of total)	15,7%	13,2%	11,7%	13,7%	19,8%
Turbine/Pump (% of total)	35,4%	39,7%	49,1%	60,2%	62,1%
Grid Connection (% of total)	6,8%	1,1%	1,8%	4,2%	4,5%
Total Investment (% of total)	100,0%	100,0%	100,0%	100,0%	100,0%

In Table 2 is a break down of the cost of different cost estimates for pumped storage plants studied in the Donegal Case Study of the project. It is clear from these data that the penstock is a very significant part of the total cost, but it is also evident that the distribution of the cost depends very strongly on local conditions. This can be seen in Table 3 where the specific cost of the penstock is shown.

Table 3 Cost of penstock per length of the different pumped storage plants, [Donegal data].

Size generate/pump (kW)	650/900	11000/16000	7500/10000	8000/11000	6000/8000
Penstock Length (m)	1500	2600	3000	1380	405
Penstock cost per length (ECU/m)	333	1654	660	717	1679
Penstock cost per length and power output (ECU/m/kW)	0,513	0,150	0,088	0,090	0,280

The main advantages of a pumped storage system compared with the other types of storage are that the technology is well known and proven and that the energy capacity will usually be quite large and not very sensitive to the investment cost. The operating and maintenance cost will usually be low compared with other types.

The initial investments costs of a pumped storage system are high due to especially the penstock cost. If the reservoirs have to be made artificially the cost of that can also be very high. In order to keep costs down it can be very beneficial to combine a pumped storage plant with a conventional plant or to see the pumped storage plant as a capacity expansion.

A limitation of the pumped storage concept is also that it is very dependent on the available sites. If the situation changes and e.g. a new feeder is installed eliminating the capacity problems of the existing feeder the value of a pumped storage plant will be much lower since it cannot be moved. The capacity of the plant is also quite fixed since it is difficult or expensive to expand the capacity.

5.2 Integrated storage concept

Integrated power control concept is shown in Figure 3.

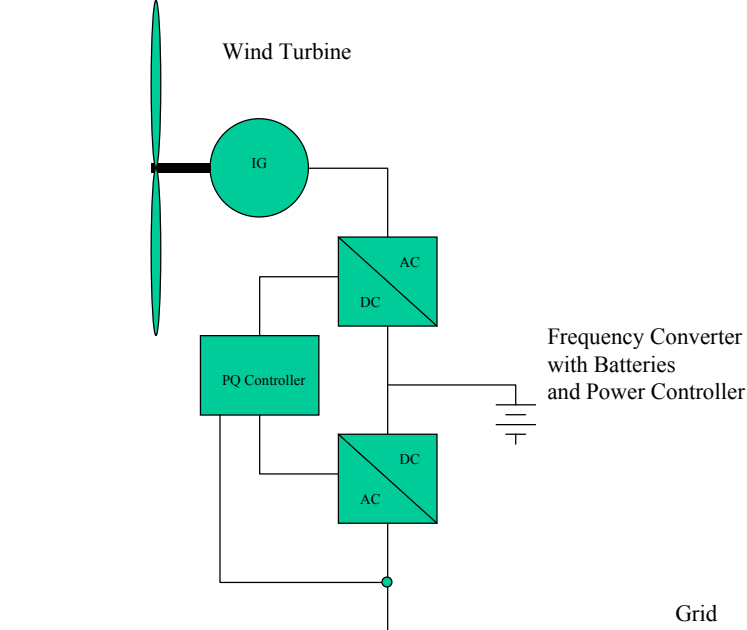

Figure 3 Integrated power control concept

In the integrated power control concept a wind turbine with variable speed is combined with a storage. The storage type will most likely be batteries but could in principle be other types.

The main idea in the integrated power control concept is to utilise that a variable speed wind turbine has the required power electronics so that a battery bank can be connected at the DC-bus bar of the power converter. The storage is distributed and placed at the individual wind turbine. It is therefore integrated both physically and the control of it with the wind turbine.

The principal components of the system are:

- Wind turbine
- Rectifier
- Battery bank
- Inverter
- Control system

The wind turbine is included because of the intimate connection between generation and the power control. The rectifier is part of the power converter (frequency converter). Most modern types of frequency converters are so called voltage source converters. This means that the battery bank can be connected at the intermediate circuit. The energy in the battery bank can then be sent to the grid via the inverter, the other part of the frequency converter. The control of the storage will of course be tightly integrated with the control of the wind turbine and the power electronics.

The control strategy can be both voltage control and power control but it will be naturally connected to the individual wind turbine. The requirements to the control bandwidth of the power electronics are so that it can handle the power fluctuations and the impact of the fluctuations on the mechanical structure and the impact on the grid. This control bandwidth will be sufficient to handle the requirements arising from the control strategies. The use of power electronics also makes it possible to reverse the direction of the power flow very quickly. This makes it possible to control the voltage or the power accurately while still keeping the storage requirements small since only the required energy has to go into the storage and the energy can be released very soon after if the voltage drops under the upper limit.

All the power from the wind turbine is converted by the power electronics and if the grid voltage is below the high voltage limit the power is inverted to the grid voltage and sent to the grid. If the voltage is above the high limit the excess power is buffered in the battery bank.

The voltage that is used to determine whether the voltage limit is exceeded or not will most naturally be the voltage measured at the low voltage side of the terminals of the wind turbine. This voltage will be equivalent to the voltage at the high voltage side of the transformer but the most interesting voltage is the voltage at the point of common connection. This voltage can only be approximated since it will be based on assumptions on the production of the other wind turbines in the wind farm. The system can not participate in the control of the voltage in the same way as centralised systems unless each of the wind turbines are equipped with communication to a central wind farm control unit that has the ability to calculate how the individual wind turbines are to control its storage unit. Modern frequency converters are able to control both the active and the reactive power but since the power electronics are distributed on the individual wind turbines it will require some central control to exploit the possibilities that this give.

The efficiency of the storage system will be relatively high since it is the additional losses in the battery that has to be taken into account. The losses in the power electronics are there to begin with. The efficiency of the batteries is in the range of 75%. The capacity depends on the battery temperature.

The additional maintenance will be checking of the batteries and exchanging of failed ones. The additional work associated with this will probably not be ex-

cessive but the lifetime of the batteries is very uncertain since the actual load pattern is not known and the consumption of lifetime given a load pattern is also not known.

The additional cost of the total system should be low due to the already existing power electronics. The total cost of the system during the whole lifetime is not very well determined since the actual lifetime of the batteries is not well defined.

The cost of batteries are difficult to obtain as it depends very much on the type on battery (lead acid, NiCad etc.), the quality (deep cycle, high current) and the number. The prices quoted are in the range of 50 ECU/kWh to 300 ECU/kWh for different kinds of lead acid batteries. Lead acid batteries will by far be the cheapest option when investment is considered. When the whole lifetime of the system is considered things are more complicated because the lifetime of the batteries depends very much on the charge/discharge pattern. Unfortunately this dependence is not known or understood very well. The actual charge/discharge pattern is also unknown

The system is very flexible since only the required storage capacity has to be resulting in small initial costs. Often there will be plans to reinforce the grid if the region is developing. It can therefore be very important to have limited investment and limited hardware lifetime will be less important.

5.3 Add-on storage concept

The add-on power controller concept is the addition of a centralised storage system to a wind farm. Both the wind farm and the storage will be connected at the same point of the grid. The storage will act as for the integrated power controller concept but instead of only handling fluctuations from one wind turbine it will be for a total wind farm.

The principal components of the add-on system are:

- Inverter/rectifier
- Battery storage
- Control system

The Inverter/rectifier controls the power flow in and out of the storage. It will typically be a self commutated frequency converter. The power rating will be relatively high since it will have to handle fluctuations for a whole wind farm. This will limit the types of available power electronic technology. New components with higher voltage and current ratings continues to appear and modern components like MCT (MOS Controlled Thyristor) used in e.g. HVDC light technologies are interesting components that are able to handle both high currents and voltages.

The energy storage will with the current technology be battery storage. The advantages of using batteries are that batteries are readily available at relatively low cost. It is scalable and relatively well known. The disadvantages are that batteries are good for energy storage but less well suited for power storage, the load pattern is not very well known and the impact of this not very well known load pattern on the lifetime of the batteries is not known.

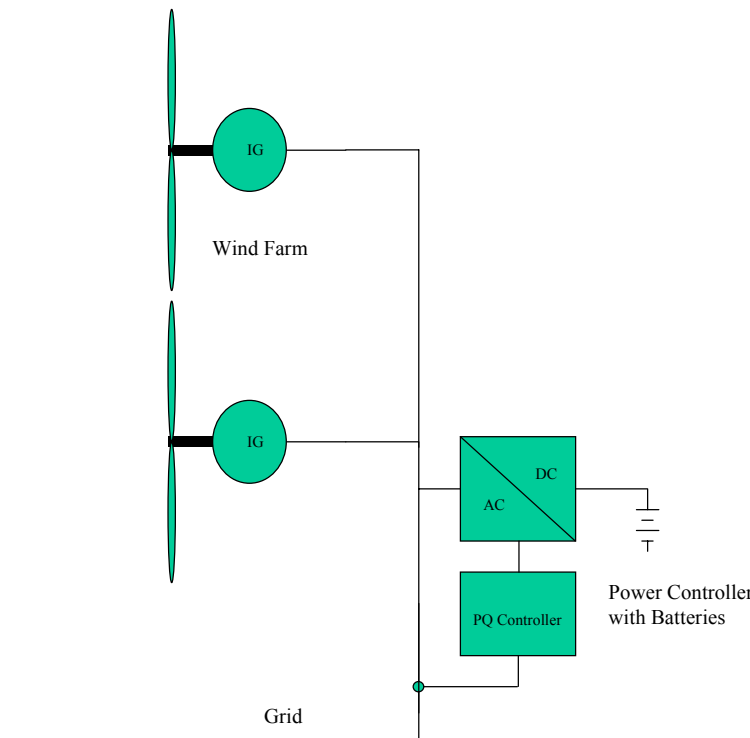

Figure 4 'Add-on' power controller

From a control point of view the add-on concept has many advantages. As for the integrated concept it can have a high control bandwidth enabling it to eliminate unwanted fluctuations including fluctuations in the flicker range. It also has the advantage of fast power flow reversal. It can be designed to operate in the same way as a pumped storage system as seen from the grid regarding voltage control. It can be conveniently designed to control the voltage at the point of common connection since the total wind farm output is easily available. The control of the storage can also be integrated with the wind farm controller.

The efficiency of the storage system is in the range of 60-70%. The power electronics has an efficiency of approx. 97% and the batteries' efficiency is approx. 75%. The efficiencies mentioned are for a complete charge and discharge cycle. They do depend on state of charge, temperature etc. The capacity of the batteries depends very strongly on the temperature.

The main requirements to the operation and maintenance of the system are to ensure that the batteries are functioning and still have the required capacity. As for the integrated type of power controller since the operating conditions of the batteries are not very well defined some kind of supervisory system will be beneficial and also detailed maintenance procedures for checking the state of the batteries.

A centralised storage system can easily be quite large. The power rating of the frequency converter will therefore also be high as well as the battery storage capacity. Especially compared to battery storage sizes in general. The investment will therefore be higher than for the integrated concept and the size most likely be less than for a pumped storage system. It will be possible to move the system should the grid be reinforced.

The cost of the batteries will be the same as for the integrated concept. The cost of the power electronics will be in the range of 70-150 ECU/kW installed.

5.4 Other configurations

Instead of using pumped storage or batteries other types of storage exist. These types of storage have different characteristics and very different costs.

Flywheels are very good for storing and retrieving power but they are not very well suited for storage of energy since the energy density is rather low. Very advanced types of flywheels exist using composites in order to manufacture a flywheel that can withstand very high rotational speeds. For these flywheels the amount of energy that can be stored is still limited.

Super-conducting Magnetic Energy Storage (SMES) uses super-conducting materials to create a coil in which the energy can be stored. The storage has a high efficiency but it still has conversion losses and losses associated with keeping the super-conducting material cold and therefore super-conducting. It is a technology that is beginning to be applied in uninterruptable power supply systems. It is a technology that competes with batteries. It has not been further investigated in this project.

Compressed air is an alternative to pumped storage. Like pumped storage it is best suited for large systems since the initial costs associated with a compressed air system are large. The actual storage of the compressed air will either be in pressure tanks or in underground caverns. Especially underground caverns can make compressed air systems economically interesting because of the big size. As it is the case for pumped storage that cost of the plants depends highly on the site where it is to be installed.

6 Power Control Assessment Framework

When assessing whether to install a power controller or not it is important to have a framework that can be used to evaluate the various options and compare them using the same measures. This framework has to take into account the grid conditions at the site in consideration, the size of the wind farm, the wind resources, the rest of the power system. The assessment has to be both technical and economic.

A power control framework could include the following:

- Fact finding
- Wind resource assessment
- Wind farm performance
- Power system performance
- Assessment of impact on grid voltage level
- Assessment of voltage stability
- Definition of possible solutions including control strategies
- Technical performance assessment

- Economical performance assessment
- Criteria/limits
- Conclusions and recommendations

The fact finding part will collect available data on the region where the power controller is under consideration. The data will include wind data, grid data, power system data, existing wind farm data, existing plans for grid and power system, possible sites for new wind farms, possible sites for power controllers. The amount of data can be extensive.

Initially are the wind resources assessed and the output from potential wind farms are calculated. The output from the potential wind farms are then used as input in a calculation of the steady state voltage level of the feeder to where the wind farms would be connected. This calculation also requires data on the feeder and on the loads connected to the feeder. The impact of the energy production from the wind turbines into the power system is also investigated. If the voltage level is not exceeded and the energy can be absorbed by the power system there is no need to investigate power control options further. If the voltage level is exceeded or the energy cannot be absorbed different control options have to be investigated. First the different options have to be defined. Some options will be more attractive in some places than in other places. Each of the different options will then have to be assessed using the same methodology. The methodology includes both the technical performance and the economic performance. Selection between the different options has to be based on some criteria e.g. least cost option that obtains a certain performance goal. Based on these assessments a conclusion with recommendations are supplied to the possible investor.

When new wind farms are considered there are many things that has to be taken into account apart from the extraction of electrical energy from the wind. The integration with the other existing and future generation is very important. Weak grid situations are often combined with a power system that is small. In these places there might be problems with absorbing large amounts of wind power at certain time of the day, but at the same time there can be problems serving the load at peak load. Adding wind power and a storage can improve the overall power supply situation.

The dynamic stability of the voltage has also to be taken into consideration. This includes assessment of the wind farms influence on the flicker level. It is very important to avoid flicker and other fast variations of the voltage since they can be very annoying.

Since the grid is weak the maximum power that can flow to the consumers can be a severe hindrance to the development of the region served by the feeder. The addition of wind power can increase the amount of power that is available to the consumers and with an additional storage it can be further increased.

These things are very important to have included in the assessment of a combined wind farm/power controller since they add additional value to the combined plant. In order to be able to assess these things various tools have to be available. These tools include:

- Load flow analysis tools
- Power system analysis tools
- Dynamic voltage stability tools and

- Tools for assessing feeder voltage dependent on wind farm and storage size and the chosen control strategy
- Economic tools

The technical tools are described in the next sections.

The economic model is based on Levelised Production Costs (LPC) and includes:

- Investment
- Value of losses
- Value of utilised production
- Maintenance
- Retrofit (of especially batteries)
- Capacity credit (of wind farm and storage if it is included)
- Lifetime

7 Simulation Tools

The assessment of the technical performance requires different tools in order to simulate the performance of the system for different conditions. These tools are described in the next sections

7.1 Load flow

Since the steady state voltage level is the most important issue when weak grids are considered tools for calculating the voltage level of a grid play a vital role in the assessment of the different alternatives.

The incoming feeder is described by a voltage and the short circuit impedance. The part of the grid under study is then specified as a set of bus bars with their loads, how they are connected and the impedances in the connections. Generation at the bus bars can also be specified.

In the project a MATLAB toolbox , [2], has been used for calculating the steady state voltage level of the feeders.

7.2 WINSYS

WINSYS, [3], is a software model used to assess the impact of wind energy in power supply systems in terms of penetration level, utilised wind energy, saved fuel etc. It also includes an economic model that calculates the value of wind energy.

WINSYS is a so-called logistic model. The models of the different components are based on their steady state characteristics. In order to calculate the performance of the system the year is divided in seasons and for each season the performance is calculated for two days, a week day and a weekend day. Each of the days are divided in hours. The program then calculates the fuel consumption with and without the addition of a new wind farm. The calculation is based on

statistical description of the wind speed. The performance of the system is then calculated for all wind speeds and weighted with the wind speed distribution.

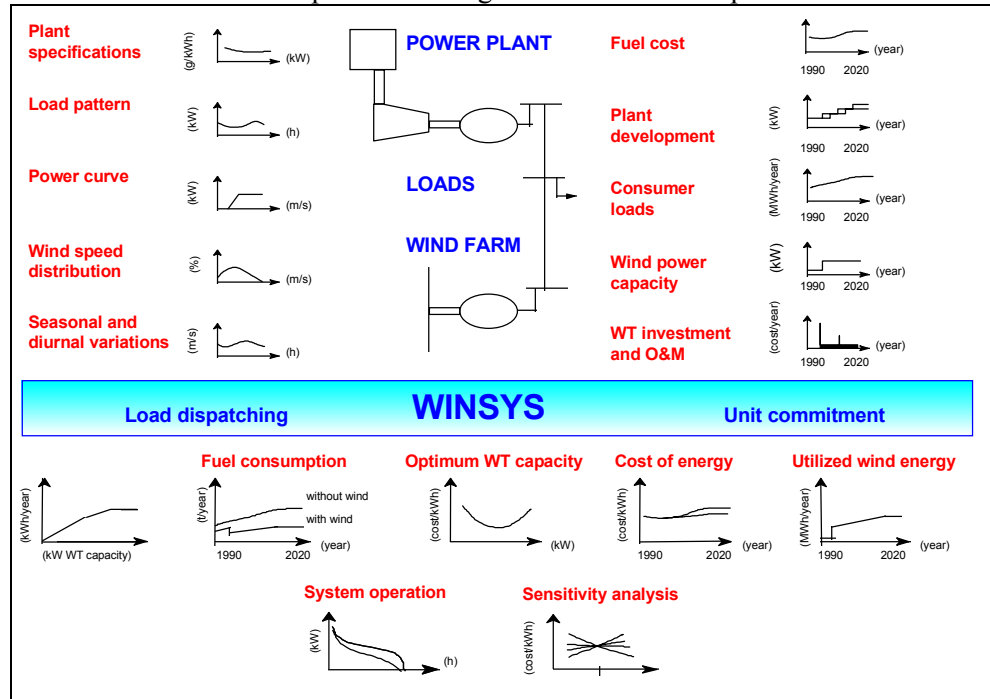

Figure 5 WINSYS: diagram showing input and output

The input to the program consists of:

- Load description: annual load and load profiles
- Description of the power plants: fuel consumption, technical minimum load etc.
- Wind Farm: number of wind turbines and their power curve.
- Wind resources: wind speed distribution
- Investments and O&M cost

The main outputs are:

- Potential wind energy production
- Utilised wind energy production
- Fuel saving
- Cost of wind energy
- Cost of energy

The limitation of the program in the current context is mainly that it cannot directly handle storage systems.

7.3 INPARK

INPARK is a dynamic simulation model that simulates the dynamic behaviour of the voltage at the point of common connection between a wind farm and the consumers. It simulates the behaviour of a wind farm by simulating each wind turbine and the interconnections in the wind farm. The model of the wind turbines includes the dynamics of the structure as well as of the generator. The internal connections include transmission lines and transformers as well as the connection to the public grid.

The inputs to model are among others:

- Wind turbine aerodynamic coefficients, mechanical and electrical parameters
- Wind speed data
- Local grid and consumer characteristics
- PCC short circuit power

The main outputs are:

- Active and reactive wind turbine and wind farm instantaneous output
- Dynamic voltage fluctuations at wind turbine bus bar
- Dynamic voltage fluctuations at PCC bus bar and local consumers bus bar
- Input to flicker calculation programs

More detailed description of INPARK can be found in [4, 5].

7.4 SimStore

SimStore is a new simulation software package, developed as a part of this project. It can simulate the steady state voltage level of a grid when both wind turbines and storage is taken into consideration.

SimStore combines a load flow calculation with a load model, a wind turbine model, storage models and control system model. SimStore then simulates a time series with a time step of e.g. 10 minutes. The main outputs are grid voltage, state of charge of storage and utilised wind energy.

8 Description of SimStore

8.1 Overall framework

SimStore is a time series based simulation model for assessment of a combined wind farm and energy storage system impact on the steady state grid voltage of a feeder depending on different control strategies of the combined wind farm storage system.

The purpose of the simulation model is be able to investigate the influence of storage size, power rating, wind farm capacity, consumer load shape etc. on the steady state voltage of a feeder.

The main input to the model is the wind speed and the load. Based on the specification of the feeder, the wind turbines of the wind farm, the storage and the consumer load shape the steady state voltage of the feeder is calculated. This can be done for different control strategies. Also are the amount of wind energy that has to be dumped if over-voltage is to be avoided and state of charge of the storage calculated.

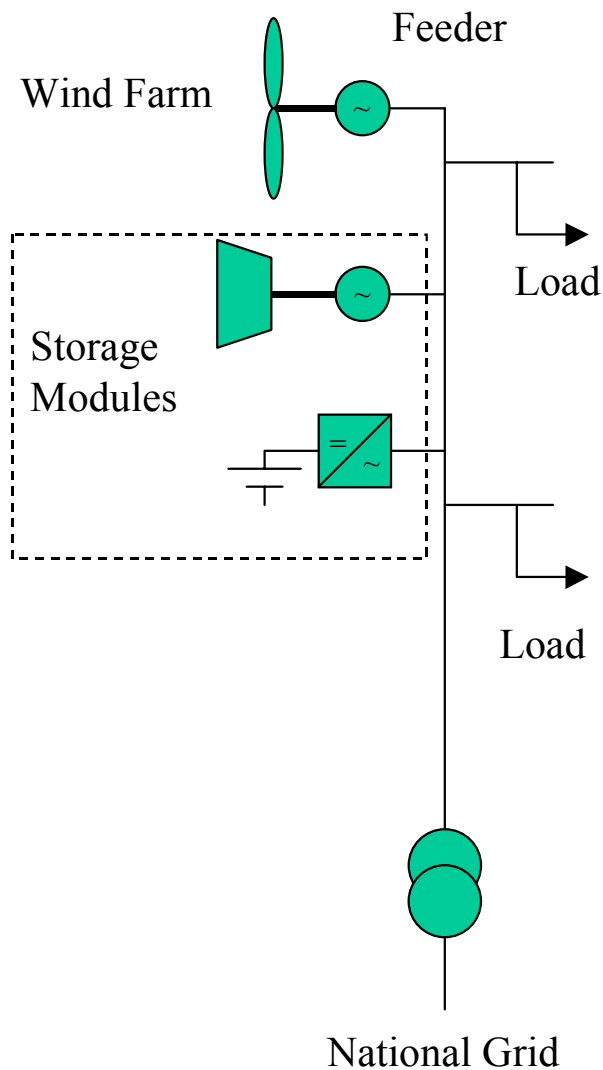

Figure 6 Main components in SimStore

8.2 Load model

The modelling of the load is based on a diurnal profile superimposed by a random variation. The load is specified by an average, a standard deviation, a maximum and a minimum. When running the program the load can be chosen to be the maximum, the minimum or the noisy diurnal profile.

8.3 Wind turbine and wind speed model

The wind turbine model is based on the power curve and a PQ-characteristic, Figure 7 and Figure 8. Each group of the wind turbines can have a different power curve and different wind input. Since the limit for the voltage is based on 10 minutes average values, the power curve is a suitable model for the wind.

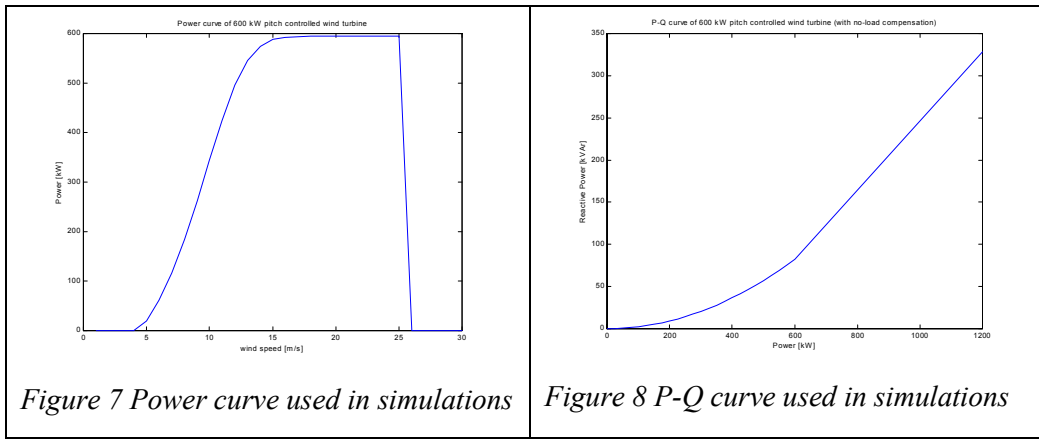

Figure 7 Power curve used in simulations

Figure 8 P-Q curve used in simulations

The time scale of the model makes it appropriate to assume that the wind speed is Weibull distributed.

$$p(u) = \frac{k}{C} \left[\frac{u}{C} \right]^{k-1} e^{-\left[\frac{u}{C} \right]^k}, \quad C \text{ is the scale parameter and } k \text{ is the shape parameter.}$$

Based on specified Weibull parameters a basic 1 year long 10 minutes time step time series is generated.

The algorithm for generating the time series is

$$x_1(t+1) = rx_1(t) + a\sqrt{1-r^2}\varepsilon(t)$$

$$x_2(t+1) = rx_2(t) + a\sqrt{1-r^2}\zeta(t)$$

$$y(t+1) = \sqrt{|x_1(t+1)|^{\frac{4}{k}} + |x_2(t+1)|^{\frac{4}{k}}}$$

where

$a = \sqrt{\frac{1}{2}C^k}$ and r is an empirically determined autocorrelation, here chosen to be 0.952 given a good fit to the Weibull distribution as well as the Von Karman spectrum. C and k are the Weibull parameters. $\varepsilon(t)$ and $\zeta(t)$ are two independent Gaussian distributed random variables.

8.4 Storage models

Two storage models have been implemented. One is an energy transfer model for modelling pumped storage, the other is a battery model.

The pumped hydro storage model handles the energy flow in and out of the reservoir with a given efficiency in generation and pumping modes.

The battery model includes a more detailed state of charge description as well as a more detailed loss description. The model is based on the KIBAM model, [6].

Pumped storage model

The pumped storage is modelled at an energy flow in and out of a limited reservoir. This reservoir is the upper reservoir of the pumped hydro plant. The lower

reservoir is assumed to impose no limits. There are limits on the capacity of pumping and generating as well as pumping and generating efficiencies.

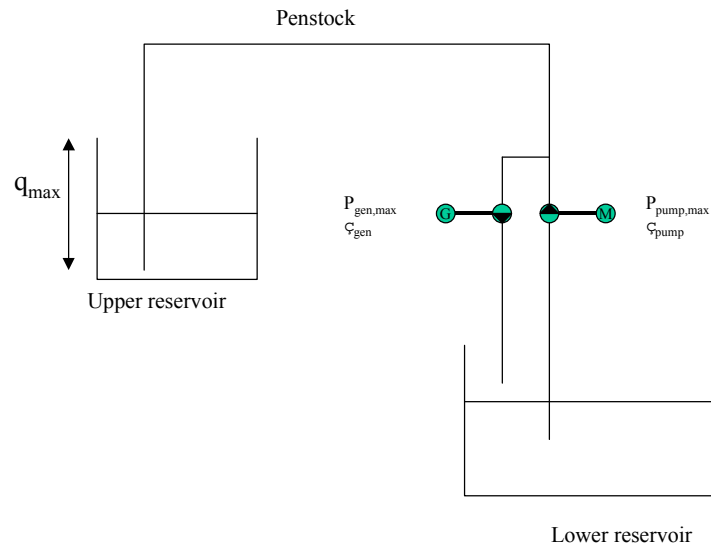

Figure 9 Pumped storage model

If the system is pumping it is described by

$$q(t+1) = q(t) + P_{pump} \eta_{pump} \Delta T$$

P_{pump} is measured at the grid.

If the system is generating it is described by

$$q(t+1) = q(t) - P_{gen} \frac{1}{\eta_{gen}} \Delta T$$

P_{gen} is measured at the grid and

$$P_{pump} \leq P_{pump,max} \quad , \quad P_{gen} \leq P_{gen,max} \quad \text{and} \quad 0 \leq q \leq q_{max}$$

Battery storage model

The battery model is based on the battery model proposed by Manwell, [6]. The battery is modelled as two connected reservoirs.

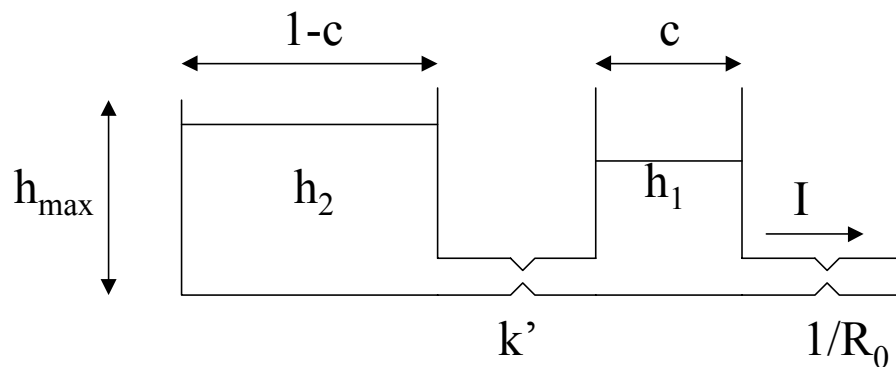

Figure 10 Battery model

The total capacity of the battery, q_{max} , is divided in two reservoirs. The first reservoir has a capacity of cq_{max} and it represents the charge that is readily avail-

able. The other reservoir represents the charge that is chemically bound. There is therefore a delay before the bound charge is available. The size of the second reservoir is $(1-c) q_{max}$.

Between the two reservoirs there is a conductance representing the reaction time of changing the bound charge to unbound charge or vice versa. There is also a conductance between the first reservoir and the power electronics.

The charge of the battery is the sum of the charge in each reservoir.

$$q = q_1 + q_2$$

It can be described by two coupled differential equations

$$\dot{q}_1 = -I - k'(h_1 - h_2)$$

$$\dot{q}_2 = k'(h_1 - h_2)$$

h_1 and h_2 are the heads of the two tanks and k' is the conductance between them.

As the model is included in a static model the differential equations are solved given the equations

$$q_1 = q_{1,0} e^{-k\Delta T} + \frac{(q_0 kc - I)(1 - e^{-k\Delta T}) - Ic(k\Delta T - 1 + e^{-k\Delta T})}{k}$$

$$q_2 = q_{2,0} e^{-k\Delta T} + q_0(1-c)(1 - e^{-k\Delta T}) - \frac{I(1-c)(k\Delta T - 1 + e^{-k\Delta T})}{k}$$

with the parameters

$q_{1,0}$ unbound charge at beginning of time step

$q_{2,0}$ bound charge at beginning of time step

q_0 total charge at beginning of time step

$k = k' / [c(1-c)]$

ΔT time step of model

These two equations describe the state of charge of the battery. I is the discharge current.

The voltage of the battery is described by

$$V = E - R_0 I$$

where

V is the voltage of the terminals of the battery

E is an internal voltage

R_0 is the internal resistance

I is the discharge current

The internal voltage E depends on the state of charge and on the rate of charge discharge.

$$E = E_0 + AX + \frac{CX}{D - X}$$

where

E_0 is the fully charge internal open circuit voltage

A is a parameter describing the linear response to SOC

C, D are describing the behaviour of the voltage at the end of charge/discharge.

$$X = q_{out} \frac{q_{max}}{q_{I,max}}$$

where

q_{out} is the charge removed during the time step

q_{max} is the maximum charge

$q_{I,max}$ is the maximum charge at a discharge current of I

The parameters can be found from manufacturer's datasheets. This is one of the strong points of the model.

The battery is subject to several limits:

$I_{b,c,max}$, $I_{b,d,max}$ maximum charge/discharge current to avoid physical damage of battery

$I_{c,max}$, $I_{d,max}$ maximum charge/discharge current to avoid over/under charging of battery

I_{max} maximum current in power electronics

P_{max} maximum power in power electronics

The energy going in to the battery is

$$E_{charge} = P_{charge} \eta_{PE} \Delta T$$

and the energy going out of the battery is

$$E_{discharge} = P_{discharge} \frac{1}{\eta_{PE}} \Delta T$$

where the power is measured at the grid and the energy is measured at the battery terminals. The internal losses of the battery are calculated by the battery model as:

$$P_{batt,loss} = |E - E_0| I + R_0 I^2$$

It is noticed that the losses are very dependent on the correct modelling of the voltage as well as the internal resistance.

8.5 Control system

The control model has to parts.

The first part is the determination of the amount of energy flowing in or out of the storage. This amount depends on the chosen control strategy.

The second part determines whether the first requirement can be satisfied based on the limitations of the storage.

The sequence in the calculations is:

- Calculate the voltage with wind power and load but without storage.
- Determine the power flowing in or out of the storage based on the control strategy and the previous calculated voltages.
- Check for limitations in the storage system. This includes full storage, limitations on current etc.
- Calculate voltages with wind power, load and storage.

Different control strategies can be implemented. Basically two have been investigated: A voltage peak shaving strategy and a voltage peak shaving strategy with tariff control.

9 Simulation Results

To illustrate the model a system with 6 wind turbine in one wind farm and a battery storage together with the wind farm at the end of a medium voltage feeder (38 kV). On the same feeder are several consumption centres (towns) connected.

The specification of the Letterkenny - Derrybeg 38 kV feeder and loads is given Figure 11. For the load flow analysis the loads are assumed to have a power factor of 0.8, except for the wind farm at Cronalaght which is assumed to be operated at a fixed power factor of 0.95 (consuming reactive power while producing active power).

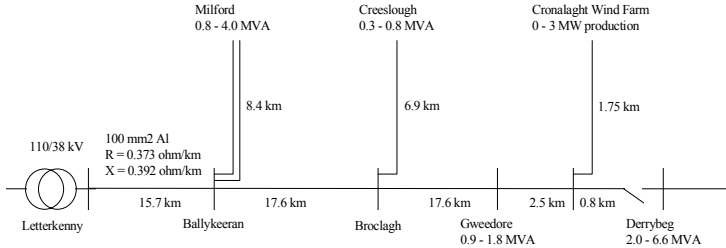

Figure 11 Data for Letterkenny - Derrybeg 38 kV feeder with indication of minimum and maximum loads.

The duration of the simulation is 4 weeks with a time step of 10 minutes.

In Figure 12 and Figure 13 are the inputs to the system shown for a five day period. The inputs are the wind speed, the wind turbine power and reactive power production and the active and reactive load for the 3 bus bars with consumer load. The diurnal load pattern is noticed. The situation simulated is with the standard load pattern where minimum, maximum and standard deviation of the load are specified. The installed wind turbine capacity is 6*600kW, the add-on storage system is rated at 2MWh battery storage and 0.5 MW power electronics. It is operated at a power factor equal to 1.

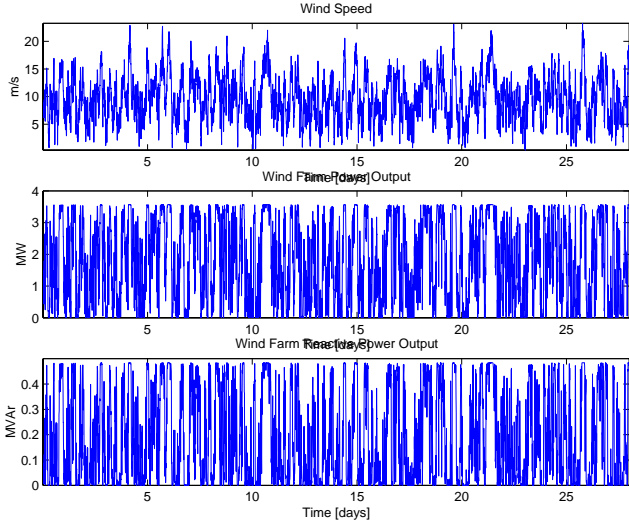

Figure 12 Wind speed, active and reactive power input time series.

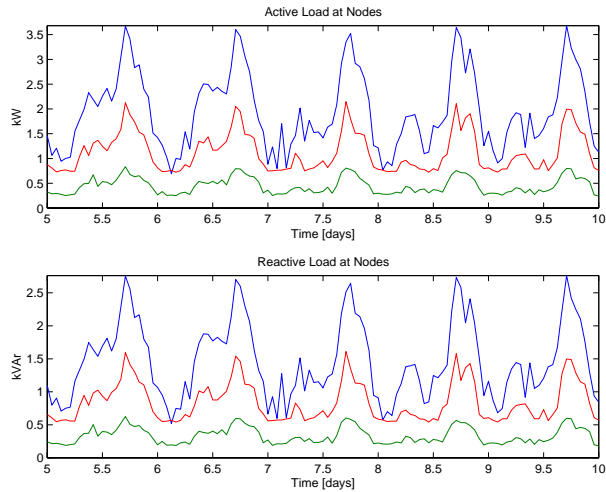

Figure 13 Active and reactive consumer load. (Top: Milford, Middle: Creeslough, Bottom: Gweedore)

In Figure 14 in the upper graph is shown the grid voltage at the point of common connection. The two lines in the graph are without storage (blue) and with storage (green). The light blue is the upper voltage limit for the grid. The voltage at the point of connection is as expected high when the load is low and vice versa. It is seen how the time in which over-voltage occur is reduced by the addition of a PQ-controller. When the voltage reaches the upper limit the controller determines the power needed to be absorbed in order to keep the voltage from increasing further. The batteries are charged. If the conditions (low load and wind power output) are so that the batteries do not have the required capacity the controller of the batteries will limit the power. A situation with surplus wind power will then occur. A situation like this can be seen starting at day 6 in the figures. It is also seen that the size of the PQ-controller is too small to eliminate over-voltages. In the lower part of the figure is shown the amount of wind energy surplus that has to be dumped due to the limitations of the PQ-controller if over-voltages are to be completely eliminated.

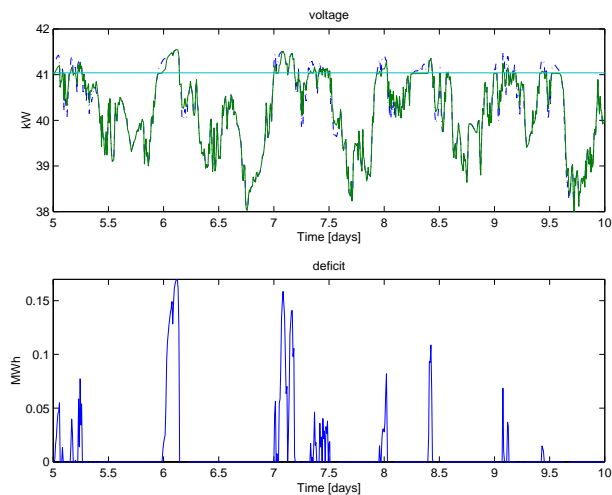

Figure 14 Voltage at point of common connection with and without PQ-controller (upper graph) and energy deficit (lower graph).

In the next figure, Figure 15, is shown the battery voltage and the State Of Charge (SOC) of the battery storage. When this figure is compared with the previous figure it is noticed that the over-voltages occur when the battery fully charged but also in situations where it is not fully charged. The reason for this is limitations in the capability of the battery to absorb power due to limitations in the current. The battery controller limits the current on order to ensure that the battery is not overcharged. The limitation is the reaction time of the battery. If power was fed into the battery it would not be converted to energy stored in the battery but it would instead be dissipated as gassing or heat. The modelled battery voltage indicates how the voltage changes with SOC and current. Further investigations have shown that the losses in the battery are inadequately modelled. The main problem is the modelling of the battery voltage.

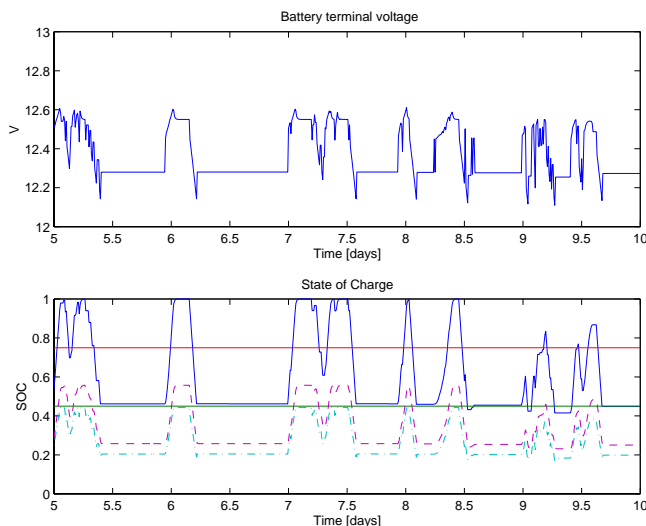

Figure 15 Battery voltage and state of charge of the two reservoirs (available: dash dot, bound: dash) and total (full).

10 Performance Indications of PQ-controllers

10.1 Technical performance

The performance of different PQ-controllers has been investigated using Sim-Store. The simulated cases are all based on the situation in the case study in County Donegal in Ireland. The grid is as in Figure 11. The wind is assumed Weibull distributed with the parameters $C=10.9\text{m/s}$ and $k=2.2$. The annual potential wind energy production per wind turbine is 2600 MWh.

Situations with

- 6-15 600 kW wind turbines connected to the feeder at the far end.
- battery storage sizes of 2MWh and 10MWh and power ratings of 0.5MW, 1MW, 2MW

- pumped storage sizes of 2MWh, 10MWh and 50MWh and power ratings of 1MW, 2MW and 6MW are simulated. The simulation period is 4*7 days with a time step of 10min.

The situation without any PQ-controller is shown in Figure 16. In this figure the amount of wind energy that has to be dumped in order to avoid over-voltages is shown for the different amounts of installed wind turbine capacity. For the smallest wind power capacity the amount is approx. 5% increasing to 35% when 9MW is installed. The impact on the amount of dumped wind energy and on the probability of over-voltages is investigated in the next figures.

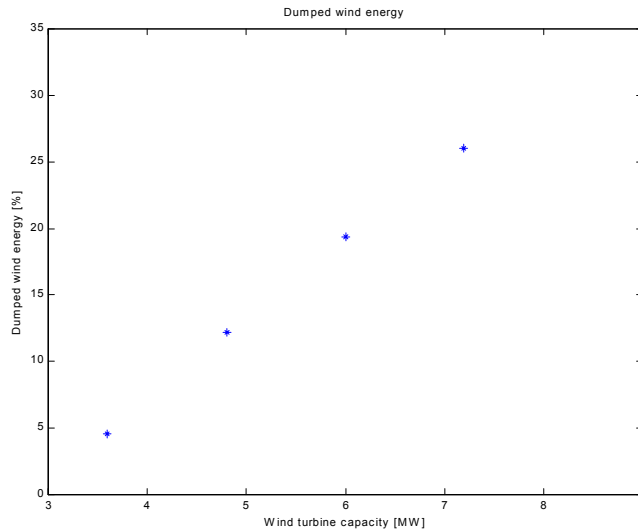

Figure 16 Percentage of wind energy production that has to be dumped if over-voltage situations are to be avoided.

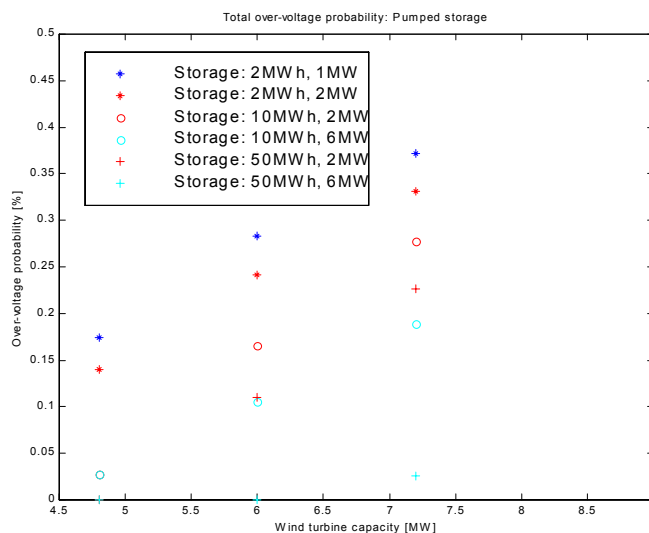

Figure 17 Total probability of over-voltages for different pumped storage sizes and different power ratings. (storage capacity has same symbol, power rating has same colour)

The impact of different storage sizes and power ratings for a pumped storage is shown in Figure 17. It is seen that a relatively large storage capacity is needed

in order to eliminate occurrence of over-voltage. The storage has to be larger than rated output from the wind farm for two hours in order to avoid over-voltages. The impact of the power rating is e.g. seen at the large storage size (50MWh, + in the figure). When 8*600kW is installed the over-voltage probability is zero for both power ratings. When the installed capacity is 10*600kW it is still zero in the case of 6MW power rating whereas it is higher than 10% in the 2MW case. The power rating can be determined by load flow calculations. In order to determine the storage capacity it is necessary to use a simulation model.

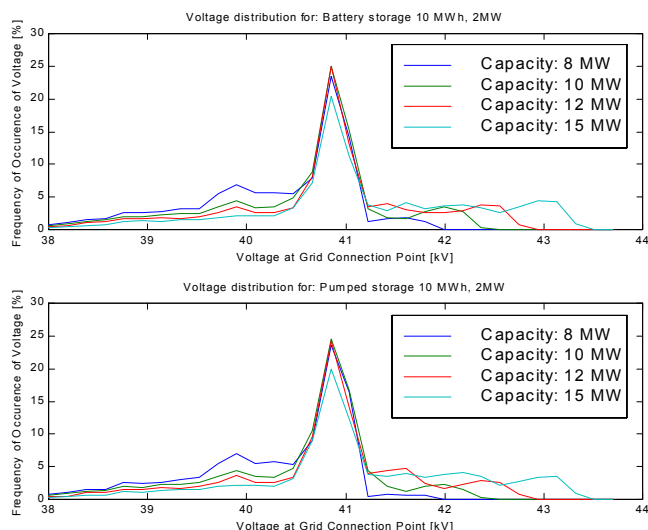

Figure 18 Voltage distributions for battery storage and pumped storage of the same nominal capacity values with different installed wind power capacity.

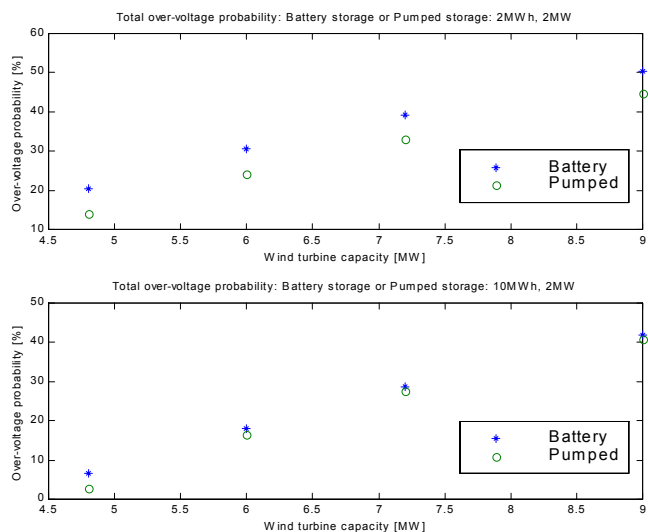

Figure 19 Total over-voltage probability for battery storage and pumped storage with the same nominal values at different installed wind power capacities.

The voltage distribution when comparing battery storage and pumped storage of the same size and rating is shown Figure 18. The limitations on the capability of

the battery to absorb power results in a higher frequency of occurrence of over-voltages, but the maximum value of the voltage remains the same. Figure 19 illustrates the differences in the two storage types as they are modelled. In the upper part the difference in over-voltage probability is mainly due to difference in the ‘real’ capacity of the storage even though the rating of the two storage systems is the same. In the lower part of the figure the capacity of the storage has been increased. It is then noticed that the performance of the two systems approaches each other and is almost identical at 9MW installed wind turbine capacity. The power rating is more important at this wind turbine capacity.

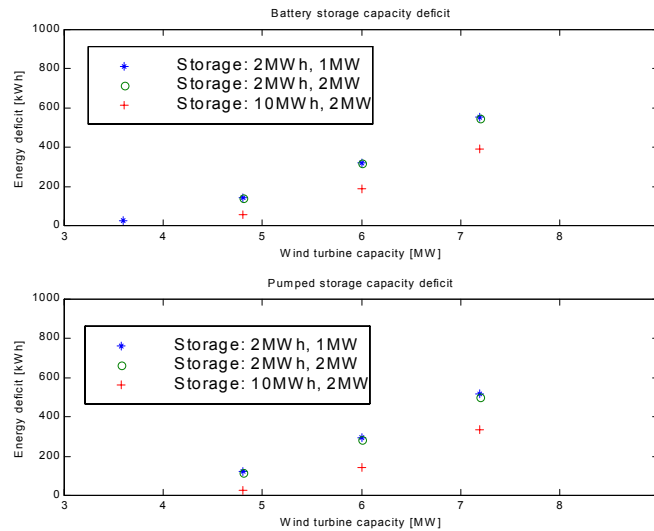

Figure 20 Energy deficit for different storage capacities and power ratings for battery storage or pumped storage.

In Figure 20 is shown the amount of wind energy that has to be dumped in order to avoid over-voltages. Again the situation is shown for both battery and pumped storage. Since the battery storage cannot absorb power as well as a pumped storage the amount of wind energy that has to be dumped is slightly higher in the battery storage case. It is also seen that the difference is more pronounced when the power rating is increased.

In the previous calculations in this section the wind farm and the storage have been connected to the grid at the same point, namely at the far end of the feeder. If the storage system is connected to the grid at a different point closer to the feeding substation the amount of wind power capacity that can be installed at the far end is decreased. This is illustrated in Figure 21. If the wind farm is installed closer to the feeding substation the capacity can be increased compared to the case where it is situated at the far end. This is also the case when it is combined with a storage system, Figure 22. It is noticed that it is better to have the wind farm connected closer to the feeding substation because the storage system can be almost freely sited further out of the feeder.

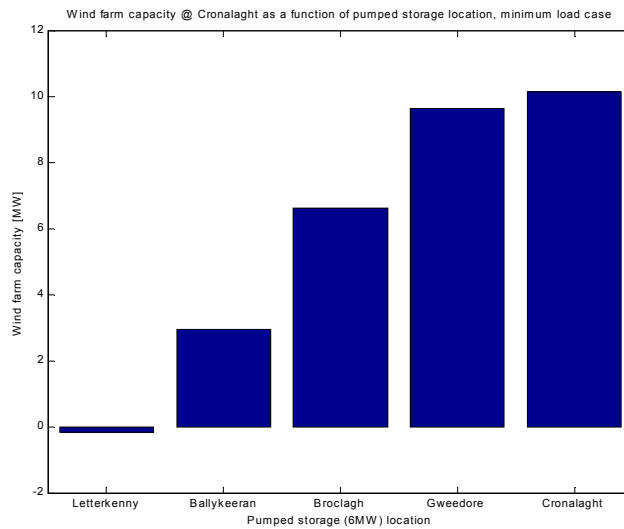

Figure 21 Wind farm capacity dependence on point of connection of storage. Wind farm connected at far end of feeder.

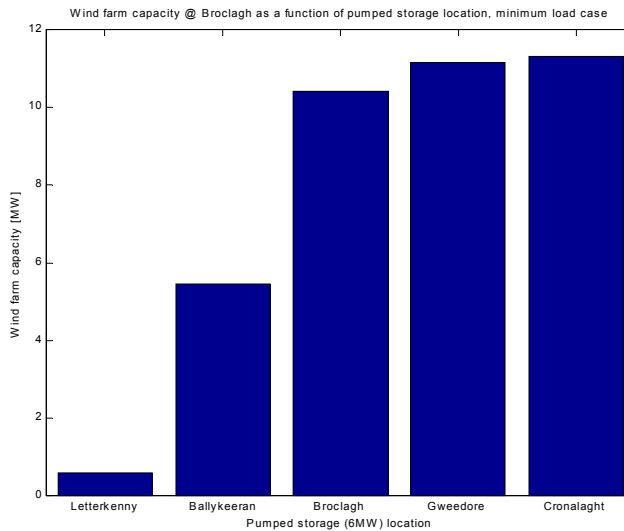

Figure 22 Wind farm capacity dependence on point of connection of storage. Wind farm connected at middle of the feeder.

If the storage is a pumped storage this can of course be a problem since pumped storage depends on the availability of suitable two lake systems. If batteries are applied the problem will seldom occur since it will be natural to have the battery system together with the wind farm.

10.2 Economic performance

The economic performance of the different ways of integrating wind energy in weak grids are compared on a net present value basis. This methodology is described in [7] in the context of wind energy.

The total cost of the option is given by:

$$TC = I + I_R(1+r)^{-t_R} - I_C + (\Delta E_{grid,loss} + E_{stor,loss} + E_{dump})V_E a$$

where

I is the initial additional investment,
 I_R is the retrofit costs,
 t_R is the year of the retrofit and
 r is the discount rate
 I_C is the additional capacity credit of the plant
 $\square E_{loss}$ is the decreased loss of the grid
 $E_{stor,loss}$ is the energy lost in the storage
 E_{dump} is the amount of dumped wind energy
 V_E is the value of the energy per unit
 a is the annuity factor

It is assumed that the operating conditions are the same throughout the lifetime of the plant. The lifetime of the plant is 20 years. The discount rate is taken as 5% per year. This gives the annuity factor of $a=12.46$. The value of the energy is taken as $V_E=0.04$ ECU/kWh. The capacity credit is taken as 2/3 of the generating capacity and the investment is compared to investment in a new gas turbine plant, 670 ECU/kW. It is assumed that the batteries have a lifetime of 10 years. The cost of grid reinforcement is assumed to be in the range 20-35kECU/km. The decreased losses in the grid due to grid reinforcement are neglected.

The necessary grid reinforcement is determined as follows: In the current grid situation is the voltage at the far end consumers determined without any wind power production and with maximum consumer load and maximum voltage at the feeding bus bar. The voltage at the load at the far end is maintained at this value when each section between two bus bars is reinforced by adjusting the feeding voltage. This feeding voltage is then used to determine the maximum amount of wind power the can be absorbed by the grid. Depending on the amount of wind turbine capacity in each case is the number of sections that has to be reinforced in order to avoid over-voltage situations determined.

The options compared are

- dumping wind energy when over-voltage occur
- grid reinforcement in order to avoid dumping of wind energy
- pumped storage at different sizes
- battery add-on storage at different sizes

The cases are

- 6*600 kW wind turbines
- 6*600 kW wind turbines, add-on storage unit (2MWh, 1MW)
- 8*600 kW wind turbines, add-on storage unit (10MWh, 2MW)
- 8*600 kW wind turbines, pumped storage unit (10MWh, 2MW)
- 12*600 kW wind turbines, pumped storage unit (50MWh, 6MW)
- 38 kV grid reinforcement

Table 4 Total investment of different options to avoid over-voltage

		I_{min}	I_{max}	I_{Rd,min}	I_{Rd,max}	Capacity Credit	I_{tot,min}	I_{tot,max}
		kECU	kECU	kECU	kECU	kECU	kECU	kECU
6*600kW	No storage, no grid reinforcement	0	0	0	0	0	0	0
6*600kW	add-on (2MWh, 1MW)	175	750	61	368	447	-210	672
6*600kW	grid reinforcement	314	550	0	0	0	314	550
8*600kW	No storage, no grid reinforcement	0	0	0	0	0	0	0
8*600kW	add-on (10MWh, 2MW)	650	3300	307	1842	893	64	4248
8*600kW	pumped storage (10MWh, 2MW)	1140	1700	0	0	893	247	807
8*600kW	grid reinforcement	666	1166	0	0	0	666	1166
12*600kW	No storage, no grid reinforcement	0	0	0	0	0	0	0
12*600kW	pumped storage (50MWh, 6MW)	3420	5100	0	0	2680	740	2420
12*600kW	grid reinforcement	1018	1782	0	0	0	1018	1782

Table 5 Total value of energy lost for different options to avoid over-voltage

		Energy stor- age loss	Energy dumped	Total for 1st year (dis- counted)
		MWh	MWh	kECU
6*600kW	No storage, no grid reinforcement	0	724	361
6*600kW	add-on (2MWh, 1MW)	41	300	170
6*600kW	grid reinforcement	0	0	0
8*600kW	No storage, no grid reinforcement	0	2592	1292
8*600kW	add-on (10MWh, 2MW)	184	715	448
8*600kW	pumped storage (10MWh, 2MW)	560	343	450
8*600kW	grid reinforcement	0	0	0
12*600kW	No storage, no grid reinforcement	0	8313	4144
12*600kW	pumped storage (50MWh, 6MW)	1870	618	1240
12*600kW	grid reinforcement	0	0	0

Table 6 Total cost of different options to avoid over-voltage

		$T_{c,min}$	$T_{c,max}$
		kECU	kECU
6*600kW	No storage, no grid reinforcement	361	361
6*600kW	add-on (2MWh, 1MW)	-40	842
6*600kW	grid reinforcement	314	550
8*600kW	No storage, no grid reinforcement	1292	1292
8*600kW	add-on (10MWh, 2MW)	512	4696
8*600kW	pumped storage (10MWh, 2MW)	697	1257
8*600kW	grid reinforcement	666	1166
12*600kW	No storage, no grid reinforcement	4144	4144
12*600kW	pumped storage (50MWh, 6MW)	2030	3710
12*600kW	grid reinforcement	1018	1782

From the above tables, Table 4-Table 6, it is seen that PQ-controllers can be cost effective. At small sizes add-on PQ-controllers with battery storage can compete with both dumping of wind energy and grid reinforcement. When the size of the wind farm is increased pumped storage is worth considering. The cost range is almost identical to the cost range of grid reinforcement. If batteries are really cheap add-on PQ-controller can be considered. Dumping of energy is the most expensive option. For large systems grid reinforcement seems to be the least cost option.

All the above assumes that the wind turbines are installed anyway. The investment in the wind turbines is excluded.

The options can also be compared with the installation of a gas turbine delivering the same amount of energy.

The fuel cost are taken as the current world market price (Jan 1999), 101USD/t or 87ECU/t. The efficiency of the gas turbine is assumed to be 35%. The energy content of the fuel is 11.86 kWh/kg.

The energy production is taken to be the same as the energy delivered to the grid by either the 6*600kW wind farm combined with the pumped storage plant or the 3*600kW in the case of grid reinforcement.

The investment in the wind farm is assumed to be 1.350kECU/kW including foundation and grid connection.

The fuel cost of energy from the gas turbine can be calculated as

$$\frac{1}{\eta} * \frac{1}{E_s} * C_f = \frac{1}{0.35} * \frac{1}{11.86} * 87 = 0.021 \text{ ECU / kWh}$$

12*600kW case

The total energy delivered to the grid is (from the simulations) 31900MWh.

An estimate of the levelised production cost (LPC) is in Table 7

Table 7 Levelised production cost of energy in the 12*600kW case

Wind Farm		Gas Turbine	
Wind turbine investment	9720 kECU	Investment (Capacity credit)	2680 kECU
Pumped storage investment	4260 kECU	Fuel cost	8347 kECU
Total	13980 kECU	Total	11027 kECU
LPC	0.035 ECU/kWh	LPC	0.028 ECU/kWh

The break even fuel cost can be calculated to be 117 ECU/t. This value is 35% higher than the current world market price but the current world market price is extremely low. It has also to be noted that only 2/3 of the installed pump capacity has been given capacity credit. The average output from the gas turbine is 90% of rated power, which is a rather high value.

The figures above give an indication of the competitiveness of the power control technology both compared with alternatives in terms of grid connection and dumping of wind energy and compared to installation of conventional power production. Both these comparisons indicate that the technology can be comparable in cost with the alternatives. Only demonstration plants of the technology can actually give improved performance figures.

11 Conclusions

Different systems for controlling the power output from a wind farm connected to a weak grid have been investigated. The investigation includes development of different control strategies, use of different storage types, development of a framework for comparing different options and tools needed as part of the framework.

The main issues in the assessment of the power control concept are the storage capacity and power rating compared to the installed wind power capacity. The model SimStore has been developed to assess that. The investigations have shown that in order to eliminate over-voltage the power rating has to correspond to what can be calculated as worst case because situations with maximum wind power output from the wind and minimum consumer load will occur. The storage capacity has to be several hours of the total wind farm output. The connection point of the storage system does also play an important role in the sizing of the components. In order to minimize the required power rating and capacity it is important that the wind farm is connected to the feeder at the same point or closer to the feeding substation than the storage system.

The economic investigations have shown that for small systems where only small amounts of wind energy would otherwise have been dumped add-on PQ-controllers with battery storage can be the least cost option compared to grid reinforcement and dumping of energy. For larger systems pumped storage is attractive and worth considering, but for large systems the least cost option is grid reinforcement.

The modelling of the storage systems needs to be improved if more accurate estimates of the performance is to be obtained. For the pumped storage systems especially the startup time and the power reversal time can play a significant role for the operation of the system and therefore also for the technical and economic performance. The description of the losses in the battery model does also need further investigation.

Because of the promising economic figures for the performance of power control technologies the next step in the development process should be actual demonstration system. This will give very important feedback both on the technical issues such as actual control of the system and also on economic issues.

Power control technology in combination with wind farms can also contribute to the development of remote regions because such technology will improve the infrastructure of the region and therefore increasing the conditions for local trade and industry.

References

- [1] IEC-1000-3-7: Electromagnetic Compatibility (EMC). IEC technical report, 1996
- [2] Chow, J.H. Power System Toolbox. User's Manual. Cherry Tree Scientific Software, 1993.
- [3] Hansen, J.C., J.O.G. Tande. High Wind Energy Penetration Systems Planning. In Proc. EWEC'94, Thessaloniki, Greece, October 1994.
- [4] Estanqueiro, A.I.(Ed.). (1998). INPARK* - A wind park and local grid dynamic model. Users Guide and Manual Demonstration Version. May 1998.
INETI/ITE - DER,
- [5] Estanqueiro, A.I, Modelacao Dinamica de Parques Eolicos. PhD. Thesis, (in Port), ITS, 1997
- [6] Manwell, J.F., J.G. McGowan, Extension of the Kinetic Battery Model for Wind/Hybrid Systems, Proc EWEC'94
- [7] Tande J.O, R. Hunter (Ed.), Estimation of cost of Energy from Wind Energy Conversion Systems. IEA, 1994

Title and authors

Power Control for Wind Turbines in Weak Grids: Concepts Development

Henrik Bindner

ISBN		ISSN	
87-550-2549-3, 87-550-2550-1(Internet)		0106-2840	
Department or group		Date	
Wind Energy and Atmospheric Physics Department		March 1999	
Groups own reg. number(s)		Project/contract No(s)	
		JOR3-CT95-0067	
Pages	Tables	Illustrations	References
40	7	22	7

Abstract (max. 2000 characters)

Presently, high wind potentials in remote areas may not be utilized for electricity production due to limited grid transmission capacity and/or difficulties in matching the electricity production with the demand. The overall project objective is to help overcome these bottlenecks, i.e. to identify and analyze methods and technologies for making it viable to utilize more of the wind potential in remote areas. The suggestion is to develop a power control concept for wind turbines which will even out the power fluctuations and make it possible to increase the wind energy penetration. The main options are to combine wind power with a pumped hydro power storage or with an AC/DC converter and battery storage. The AC/DC converter can either be an "add-on" type or it can be designed as an integrated part of a variable speed wind turbine. The idea is that combining wind power with the power control concept will make wind power more firm and possible to connect to weaker grids. So, when the concept is matured, the expectation is that for certain wind power installations, the cost of the power control is paid back as added wind power capacity value and saved grid reinforcement costs.

Different systems for controlling the power output from a wind farm connected to a weak grid have been investigated. The investigation includes development of different control strategies, use of different storage types, development of a framework for comparing different options and tools needed as part of the framework.

The main issues in the assessment of the power control concept are the storage capacity and power rating compared to the installed wind power capacity. The model SimStore has been developed to assess that.

The economic investigations have shown that for small systems where only small amounts of wind energy would otherwise have been dumped add-on PQ-controllers with battery storage can be the least cost option compared to grid reinforcement and dumping of energy. For larger systems pumped storage is attractive and worth considering, but for large systems the least cost option is grid reinforcement.

Power control technology in combination with wind farms can also contribute to the development of remote regions because such technology will improve the infrastructure of the region and therefore increasing the conditions for local trade and industry

Descriptors INIS/EDB

COMPUTERIZED SIMULATION, CONTROL, ECONOMICS, ELECTRIC BATTERIES, ELECTRIC POTENTIAL, FLUCTUATIONS, POWER SYSTEMS, PUMPED STORAGE, WIND POWER, WIND POWER PLANTS

Available on request from Information Service Department, Risø National Laboratory, (Afdelingen for Informationsservice, Forskningscenter Risø), P.O.Box 49, DK-4000 Roskilde, Denmark. Telephone +45 4677 4004, Telefax +45 4677 4013