

IPTV market development and regulatory aspects

Reza Tadayoni & Halldor Sigurdsson
Center for Information and Communication Technologies, CICT
COM, Technical University of Denmark
Building 371
DK-2800 Lyngby, Denmark
reza@cict.dtu.dk & Halldor@cict.dtu.dk

Abstract:

The aim of this paper is to analyse the development of IPTV technology / market and to discuss major regulatory parameters. A general overview of architectures and the technologies deployed for establishing IPTV services is given and the main stake holder identified, along with, the current service architecture, the available content in IPTV platforms, and the current business models. Furthermore the regulatory framework of the TV broadcast and IPTV in Europe is analysed

Keywords: Convergence, Broadband, IPTV, VoD, Triple play, Content regulation,

1 Introduction

The market for television services has been subject to radical changes through the convergence of technologies and markets. Traditional TV broadcast services are still regulated on the basis of specific content oriented measures. In Europe the basis for a European regulatory regime was settled through the TV Without Frontiers (TVWF) Directive of 1989. This approach to regulation is no longer appropriate in a world, where there are a huge variety of TV and video services, competing with the traditional Broadcast services. Broadcasters of today are competing with TV broadcast offered through the Internet and other IP networks. Furthermore there are a number of 'On demand' video / audio services that to a certain degree are comparable with programming within the traditional broadcast market.

Digitalization of TV was certainly the most radical innovation that TV industry has experienced since introduction of color TV. It is important to notice that even though digital TV was a radical changed it has mainly been kept within the broadcast industry consisting of traditional broadcast market players and using traditional broadcast business models. The increasing use of IP networks for transmission of TV and video services has radical impacts on the characteristics of TV and video services and the deployed business models. This in turn requires a more radical approach to the regulatory framework of audiovisual content, for creating a level playing-field for competition, to promote certain

audiovisual content, and for protection of minors, etc. which have been the main pillars of broadcast regulation in Europe.

The focus of this paper is on IPTV services, market and regulation. The aim of this paper is to analyse the development of IPTV technologies and market and to discuss the major regulatory parameters. Offering IPTV along side with VoIP and Internet access in broadband networks may be seen as the materialisation of convergence. Recently the IPTV services offered in broadband IP networks directly compete with major multi-channel platforms like digital cable TV and digital satellite TV. The IPTV development opens up for new possibilities for broadcasters both in terms of expansion of number of services (total removal of scarcity) and the possibility for real interactivity. Additionally, IPTV is developing in the IP world, which traditionally has not been subject for regulation.

In this paper a general overview of architectures and the technologies deployed for establishing IPTV services is described and the main stake holder are identified, furthermore, the current service architecture, the available content in IPTV platforms, and the current business models are described.

With respect to market development, three hypotheses are tested through case studies: 1) IP platforms, especially broadband platforms, are becoming a competing infrastructure for delivering of TV services. Until now, terrestrial, satellite and cable network have been the main delivery platforms and the main development has been towards digitalisation. 2) IP platforms, due to the inherent interactive component, are changing 'broadcast' in a fundamental way from a broadcast service to an *on demand* service. 3) Content providers can bypass service providers and directly offer services to the end consumers.

With respect to regulation the framework of TV regulation in Europe is analysed and the regulatory challenges in the light of technology development are discussed. Major efforts have been done within the European Commission to adjust the regulatory regime of TV in Europe to the increasingly changes that the media landscape is experiencing. This will end up in a new Directive which will replace the TVWF Directive of 1989. Some of the conclusions of a proposal to the European Directive for regulation of TV are presented shortly in the paper.

2 Technology

IPTV is a synonym for different implementations which in principle can span everything from simple broadcasting functionality to advanced interactive services. What all solutions have in common is that encoded video content is sent over broadband networks to end users where the content is decoded before it is displayed. In the context of this paper we define IPTV as commercial television services, with at least the same functionality and quality as broadcast TV. We will now look at the key technology components needed to deliver commercial IPTV.

2.1 IPTV Technologies

2.1.1 Coding and Compression

Compression technology is an integral component of IPTV as well as an active field of research, where the goal is to reduce the number of bits that are required to represent the video image. Uncompressed standard definition video requires 270 Mb/s, making compression essential prior to transmission in broadband networks. There are several compression standards to choose from, of which standards from the Moving Expert Group (MPEG), International Telecommunication Unions Telecommunications Standardization Sector (ITU-T), and Microsoft Windows Media are most widely used in IPTV.

The required bandwidth for encoded content has been constantly dropping for the past decade. In fact, over the past ten years, the bandwidth required for video has been halved every three years [Karyabwite]. MPEG-2 encoded broadcast TV in standard definition has dropped to around 2 Mbit/s and MPEG-4 / H.264 are expected to provide similar quality at 1 Mbit/s [Alcatel]. High definition TV is down to 8 Mbit/s, and is expected to drop further. With bandwidth requirements going down and access network transmission rates increasing, the previous delivery gap has been bridged, enabling IPTV.

Advancements in coding have not only resulted in lower bandwidth but also advanced functionality. New codecs, such as MPEG-4 include functions such as media objects, where parts of content displayed simultaneously on the screen can be changed, allowing everything from simple subtitle functions to changing background or textures. However, the ability of an IPTV service to offer advanced functionality is not only determined by the coding standard used but rather by combined support for functionality at all levels of the value chain, from set-top box, auxiliary systems (middleware), servers, to the content itself.

2.1.2 TV Broadcast Servers

The main functionality of most current IPTV system is providing customers with traditional broadcast TV. TV Broadcast Servers are real-time servers of linear content, which take TV channels as input and stream them out to a transmission network. There is no fixed limit to the number of channels which a server can transmit but both hardware and transmission networks have upper limits. The source of the input signal to the broadcast server limits the complexity of the IPTV broadcast services, e.g. if input signals are from satellite and do not provide selection of subtitles.

An important issue in broadcasting is sharing of server resources. If the system supports multicasting the broadcasting server only has to output one video stream pr. broadcast channel and the transmission equipment generates extra copies at the edge of the network. Alternatively, if the system only supports unicasting, the server has to output one stream pr. viewer and transmit them individually through the transmission network.

If we consider the case of a broadcasting server with 100.000 concurrent viewers of 30 channels, unicasting would require at least 100 – 200 Gb/s in throughput while multicasting would only require 30 - 60 Mb/s (0,03-0,06 Gb/s). Currently multicasting support is only supported within managed IP networks and not on the public Internet.

2.1.3 Video-on-Demand Servers

Increasingly, IPTV service providers are offering content on demand (non-linear). In contrast to broadcasting, the content is stored in encoded form on a storage server, from where users can find and select the content they want. VoD requires extensive storage capacity and higher throughput from the server and the transmission networks since all content is sent individually through unicast.

As a service enabler, VoD can be used to make additional content available (such as renting movies), providing existing content after initial broadcasting (e.g. watching content at a more convenient time), or to combine it with broadcasting to offer additional functionality (e.g. time-shifting and personal-video recoding). The additional functionality of VoD incurs higher requirements on content protection than broadcasting does and therefore VoD needs to operate within a digital rights managements system that guarantees rightful content usage.

2.1.4 Webcasting Servers

Webcasting servers are small brothers to commercial broadcasting/VoD servers. They stream video content, most often in low quality, over the public Internet for viewing on a computer screen. These servers are most often operated without any auxiliary systems such as DRM and can not be said to offer substitute or competitive services to commercial IPTV. As we will examine later in the paper, it is possible to offer commercial VoD/broadcasts over the public Internet to a limited extent, but then we do not define them as webcasting.

2.1.5 Auxiliary Systems

In a commercial environment, several auxiliary systems run in parallel to coding and transmission within an IPTV service. Among these are subscription management, billing, digital rights management (DRM), metadata etc. In contrast to traditional broadcasting, where all these functions were designed as pre-processed passive information within the data, all of the auxiliary systems in IPTV can be interactive. This allows customers to change subscription, perform instant purchases (micro payments), interact through searching, voting etc.

In general the more advanced features an IPTV system is designed to offer, the more complicated the auxiliary system becomes. This is one competence area where telecommunication operators usually have more experience than traditional broadcasting operators, e.g. in designing and deploying new communication services and operating

interactive distributed subscription and billing databases. An example could be implementing betting during a sports event.

2.1.6 Set-top boxes

In its most simple form, a set-top box is a decoder, a piece of hardware that takes in IP packets with encoded video, decodes the content and then displays it on a television. However, most set-top boxes today are mini computers that run embedded software that also facilitates user interaction through a graphical user interface. In addition to user interactivity and representation, a set-top box communicates with auxiliary systems and may include some local recoding functionality.

In modern households, several other devices than set-top boxes (such as computers and PDAs) are capable of decoding and displaying video content. IPTV has the potential of moving over to these devices but only if the content is adapted to the characteristics of individual devices. This requires advanced DRM features, and support for transcoding or scalable video codecs.

2.2 IP Based Platforms

When video is transported over a digital network, the content is sent in a consecutive flow of packets between the sender and receiver. Irregularities in transmission properties, such as packet loss and variance in packet delay can cause unwanted breaks or decrease perceptual quality of the content. In modern IP networks network access providers can control transmission properties within the boundaries of their own network. In contrast, the public Internet is a “best effort” network where no guarantees can be provided for end-to-end quality of service.

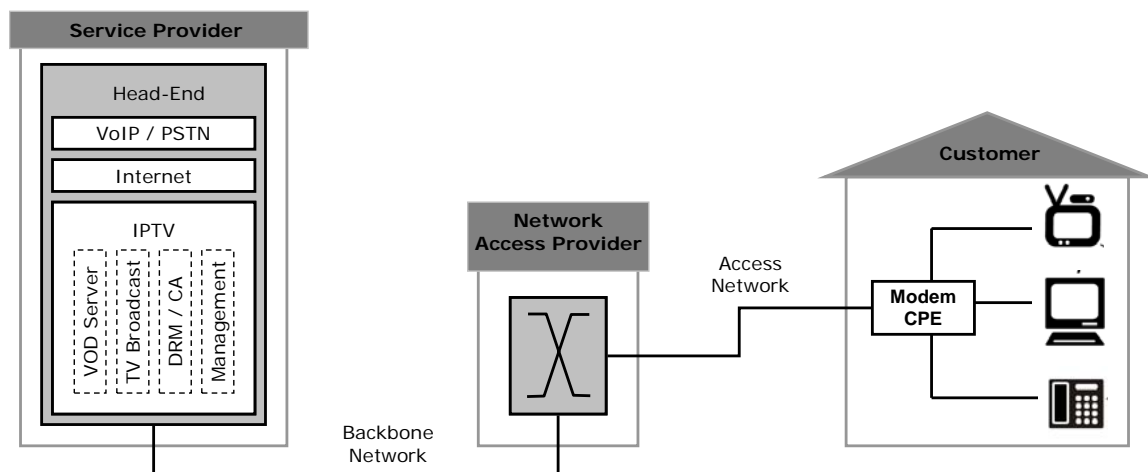

Figure 1: Typical IPTV deployment

2.2.1 Managed IP Networks

There are several advantages in providing IPTV services over managed IP networks. Apart from higher transmission quality level, advanced transmission functionality such as multicasting can reduce network load. Depending on business model applied, the tight relationship between network access providers and customers can be utilised in service provisioning. Furthermore, intellectual property rights can be guarded better when the flow and access to content can be monitored, resulting in more simple Digital Rights Management / Conditional Access systems. Along with tighter participation of the networks access provider in offering IPTV, comes a larger role in the value chain, e.g. through revenue sharing.



Figure 2: Typical Value Chain for IPTV in managed IP networks

2.2.2 Internet

Providing IPTV services over the public Internet detaches the service provider completely from influence on data transmission making the service subject to uncontrollable fluctuations in transmission quality. This can partly be compensated through scalable (adaptive) codecs or increased playback buffering at the customer side. However, if bottleneck throughput is below consumption rate, content can not be watched in real-time. Currently bottlenecks on the public Internet make it unrealistic to offer real-time broadcasting in high quality between countries / continents. Marketing and trust also becomes a larger problem when customers are doing business over the public Internet.

For most network access providers, IPTV traffic over the public Internet is unwanted as it reduces participation in the value chain and causes overload on shared bandwidth due to transmission inefficiency since all streams are sent individually using unicast. However, for content providers that wish to reach a broad customer group without having to make revenue sharing agreements with content aggregators and network access providers, the Internet provides an inexpensive starting point. However, with adaptation and popularity of IPTV, service providers are likely to be forced into closer ties with network access providers.

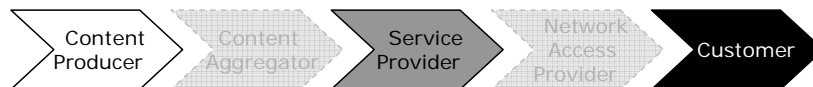

Figure 3: Value Chain for IPTV over the public Internet

2.3 Infrastructure Platforms

Properties of transmission infrastructures have direct influence on service capabilities. The main control parameters are: available bandwidth, topology, and symmetry of the return channel. With more dedicated bandwidth comes flexibility in content selection and with two way communication comes interactivity. Since satellite and terrestrial

broadcasting do not have a return channel and are focused on DVB we will not describe them in the context of IPTV.

If we assume that IPTV is the only source of TV in the home, a typical family consumption pattern in the near future could be 1 HD channel, 2 SD channels, 2 VoIP lines, and advanced communication services, yielding an accumulated bandwidth requirement of approximately 20 Mb/s pr. household. We will now evaluate the available infrastructure platforms based on these properties.

2.3.1 FTTH

Fibre has already become a dominant medium in metro and backbone networks. Fibre-to-the-Home (FTTH) is a synonym used for emerging access networks that uses optical fibre in the first/last mile. Several network architectures and technical implementations of FTTH exist as the technology is still being refined and developed. However, in general, the variants can be categorised as either Active Star, or Passive Optical Networks (PON).

Fibre has a virtually unlimited bandwidth capacity and is therefore capable of meeting all traffic demands of multimedia services and thus providing a “future-safe” solution for service evolution. IPTV is the dominant method of offering television services in FTTH, apart from two of the PON standards, BPON and GPON, which additionally define overlay broadcasting. In overlay broadcasting, the 1550-1580 nm frequency range is used for one-way radio frequency transmission, resulting in very similar services to those offered in CATV.

2.3.2 DSL

Digital Subscriber Line (DSL) technology reuses the copper twisted pair infrastructure to offer broadband services by using the frequency range above PSTN for high speed data transmissions. There are several variants of the DSL technology, such as Asymmetric (ADSL), Symmetric (SDSL) and Very high bit rate (VDSL). Each of these variants has distinctive characteristics but to generalise, the decisive properties are bandwidth, range, and symmetry. These three parameters are to a large extent internally related, where high speed or symmetry limit reach, and vice versa.

In first generation ADSL, the transmission capacity was limited and equipment at the operator side did not support commercial video services. The underlying transmission was based on the ATM standard and shared backbone capacity often limited to 155 Mb/s for several hundred customers. New generation of DSLAMs are increasingly moving to Gigabit Ethernet backbone connections, multicast support, and support of virtual channels that enable service differentiation and thus quality assurances for IPTV.

DSL now fosters IPTV development through operators that want to diverge and squeeze themselves into the lucrative entertainment market. To accomplish this, DSL operators are upgrading and moving equipment closer to customers. To offer one standard definition IPTV channel in DSL, the copper distance from customers to nearest

aggregation point has to be less than 3 Km, and less than 1,5 Km for the previously described household requirement of 20 Mb/s. In both cases the upstream bandwidth is limited.

2.3.3 Cable Networks

Most cable networks were designed to provide one-way broadcasting of analogue television content in the frequency range from 88 to 860 MHz. Recently, cable infrastructures are being upgraded to offer digital broadcasting and two-way broadband services. Many technical variants exist but most are based on using the frequency band from 5-65 Mhz for upstream traffic and a portion of the downstream broadcasting channels for IP traffic. Due to the established TV analogue broadcasting and planned conversion to digital broadcasting, IPTV is neither a natural nor likely migration step for most cable operators.

Cable is a shared medium (i.e. several homes share a branch in a tree topology) where smaller access segments share the available bandwidth. Cable networks are therefore ideal broadcasting rather than for video on demand. Given network upgrades and smaller access segments, bandwidth capacity of cable is ample and can theoretically support all types of multimedia.

2.3.4 Wireless Networks

Current IP based wireless network technologies, such as Wi-Fi and WiMAX are not well suited for IPTV. There are several technical and economic reasons for this such as bandwidth limitations and cost, variations in transmission quality, lack of multicast support etc. Although research is focused on solving many of these limitations, in the opinion of the authors, wireless networks can not be seen as a realistic platform for IPTV in the near future.

2.4 Standardisation

In contrast to the strictly defined format and characteristics of traditional broadcasting, IPTV lacks an overall standardized framework for end-to-end delivery. Only a few aspects of such a system have been deeply studied and standardized, and a lot of issues, new to both the broadcasters who produce the content and to operators ensuring its delivery, have yet to be addressed [Fleury,2005]. The result is a broad diversity in implementation where most deployments are based on proprietary solutions. This has been identified as a major incubator to adoption and development of IPTV.

Realising the negative effect of market fragmentation and lack of interoperability, large players from different areas in the value chain have teamed up to produce a holistic solution. One of the most promising platforms is Microsoft IPTV, where Microsoft as a server and middleware provider has teamed up with Alcatel, a dominant infrastructure provider. Repeated delays and implementation problems within the Microsoft IPTV platform alone serve as a reminder of the colossal task of standardising IPTV.

Standardisation projects are further from materialising but important pieces of the puzzle are on its way e.g. through MPEG-21, which defines a framework for the creation, delivery and management of multimedia content, MHP which standardises middleware and representation of content. Traditional standardisation bodies such as ITU and IETF are also turning their attention towards IPTV [ITU] [IT-Wire]. On EU level there is however not a general consensus around public involvement, as a recent EU Communication concludes “that mandating EU-wide standards [...] would not contribute significantly to the growth of interactive digital television in Europe, and could have significant negative effects” [EU,2006].

2.5 Interactivity

Interactivity has been hailed as one of the major strengths of IPTV, where the return channel of the infrastructure platforms on which it is deployed allow the customer to communicate with the service provider. Interactivity can be divided in levels based on how deep into the system it goes. The most simple level is “basic interactivity” that allows users to select and change channels etc. In some of the infrastructure platforms such as DSL, there is only a limited amount of network bandwidth and therefore basic interactivity goes back to the DSLAM where it gets processed. Although limiting as such, this (as well as intelligence in set-top boxes) can be used to report viewing habits and conduct popularity measurements in IPTV. The next level of interactivity is “VCR-like” where viewers can break free from linear viewing by pause, rewind, and fast-forward. Implementing these functions puts a much higher burden on the video delivery system and network transmission since the nature of the viewing goes from broadcasting to VoD. The last level of interactivity is “Content-oriented interactivity” where users are given the ability to respond directly to the content itself. This can be everything from responding to an advertisement to controlling the outcome of a program.

Despite being a gateway to new and advanced services, interactivity in IPTV represents possibility rather than a built in feature. To offer advanced functionality, all the equipment from the user to the production studio has to support the same features. This will require a tighter interaction and cooperation between different actors of the value chain. Until IPTV grows in market share content providers are not likely to put a lot of efforts into supporting interactivity, creating a hen and egg problem. In the meantime, telecom operators are more likely use their core competences in ICT to focus on interactive set-top box functionality where games, betting etc. can be conducted without integration with content.

2.6 DRM and Conditional Access (CA)

Digital Rights Management (DRM) systems include a number of technologies, which are used to protect the copy right of digital content. For example, the Open Mobile Alliance (OMA) defines the scope of their implementation of DRM ‘to enable the controlled consumption of digital media objects by allowing content providers to express usage rights, e.g., the ability to preview DRM content, to prevent downloaded DRM content

from being illegally forwarded (copied) to other users, and to enable new business models with super distribution of DRM content'¹.

In the broadcast world the protection of content rights has been implemented using Conditional Access (CA) systems, with the aim of controlling provision and consumption of TV/radio channels. The CA systems were first implemented in the analogue satellite and cable networks. The aim was to establish a business model for the provision of Direct To Home (DTH) satellite services and to be able to offer premium pay TV the cable networks, by simply excluding the non-payers. CA systems are further developed in the digital broadcasting and are also deployed in the digital terrestrial broadcast provisions. The scope of CA systems is however more than excluding the non-payers

The CA system consists mainly of two functions:

- Encryption / decryption of signals. The signals are encrypted in a way that only authorised users are able to decrypt and use them. The information necessary for decryption of the signal is transmitted alongside with the signal.
- The CA management. The management function has the task of network management and subscriber management. The CA management system consists of two parts; Subscriber Management System (SMS) and Subscriber Authorisation System (SAS). The SMS is the administrative system dealing with the consumer bases and storing data on the consumers, the services they subscribe, and facilitating financial transactions. The SAS is a technical system that implements processing of the data from SMS into commands that can be used by the receiver equipments. These commands are transmitted alongside with the data to the decoders and facilitate decryption of the signals the users are authorised to use.

3 Market

The past 5-6 years, we witnessed the emergence of a huge amounts of '*on demand*' video services on the Internet, specific '*Internet TV*' channels, and '*time shifted*' versions of part of programming from traditional broadcasters. This development has been intensified in the recent years, where the quality of streaming video signals are getting better and approaching the quality levels known from traditional TV services. Furthermore, in recent years, broadband operators deliver IPTV services in their managed IP networks. Here, it is possible to deliver even better quality than traditional broadcast TV and many broadband operators have plans for the provision of HDTV based in IPTV technology. Also in the managed IP networks a great deal of video content, mainly feature movies, is available in the VoD provisions. The IP-VoD is mainly based on client server architectures, but in the future development P2P can be used as a more efficient content organization architecture.

¹ http://www.openmobilealliance.org/release_program/drm_v1_0.html

Market development of IPTV depends to a high degree on the development of broadband market. However, within the broadband infrastructures different business models are emerging. In the following first development of broadband is discussed shortly, in the next subsection (3.2) some case studies are given and in the third subsection (3.3) an analysis of IPTV market development is given.

3.1 Development of Broadband

Broadband is growing fast and its role in creation of values in the new economies is more and more recognized. In the 15 EU member states the number of broadband households has more than doubled in one and a half year, from app. 9 million in mid 2002 to app. 23 million in the beginning of 2004². Also other developed regions especially the US and the South East Asian market have experienced tremendous growth in penetration of broadband. In South Korea about 96% of online users have broadband connectivity³. In Europe the development has been dominated by DSL technology, however other broadband technologies count for a substantial part of broadband households and growths rate. In the developing countries traditional broadband like DSL will play a minor role and the development of broadband will mainly be influenced by the development of new wireless technologies.

Table 1 shows some recent statistics on the development of broadband.

Table 1: Broadband subscribers per 100 inhabitants, by technology, June 2005

Country	DSL	Cable	Other	Total*	Rank	Total Subscribers
Korea	13.9	8.9	2.7	25.5	1	12 260 969
Netherlands	13.6	8.9	0	22.5	2	3 642 315
Denmark	13.2	6.1	2.4	21.8	3	1 176 637
Iceland	21.0	0.3	0.4	21.7	4	63 553
Switzerland	12.7	7.2	0.4	20.3	5	1 515 446
Canada	9.4	9.7	0.1	19.2	6	6 142 662
Finland	16.3	2.2	0.2	18.7	7	978 600
Belgium	11.0	7.3	0	18.2	8	1 899 652
Norway	14.8	2.5	0.9	18.2	9	836 060
Sweden	11.3	2.7	2.5	16.5	10	1 482 843
Japan	11.0	2.4	3.0	16.4	11	20 953 090
United States	5.5	8.0	1.1	14.5	12	42 645 815
United Kingdom	9.7	3.8	0	13.5	13	8 095 000
France	11.9	0.8	0	12.8	14	7 935 900
Austria	7.0	5.4	0.1	12.5	15	1 025 036

² COCOM 2004

³ ITU 2003

Luxembourg	10.4	1.3	0	11.8	16	52 920
Australia	8.5	2.4	0.1	10.9	17	2 183 300
Germany	9.9	0.3	0.1	10.2	18	8 439 732
Italy	9.4	0	0.6	10.0	19	5 783 319
Portugal	5.1	4.7	0	9.9	20	1 031 491
Spain	7.0	2.2	0.1	9.3	21	3 949 234
New Zealand	6.4	0.3	0.3	6.9	22	283 798
Hungary	2.9	1.6	0.1	4.6	23	469 186
Ireland	3.5	0.4	0.5	4.3	24	175 500
Poland	2.5	0.7	0.1	3.3	25	1 250 000
Czech Republic	1.8	1.0	0	2.8	26	284 200
Slovak Republic	1.2	0.3	0.1	1.6	27	86 958
Turkey	1.1	0	0	1.2	28	862 843
Mexico	0.8	0.2	0	1.0	29	1 051 854
Greece	0.8	0	0	0.8	30	93 287
OECD	7.2	3.8	0.8	11.8		136 651 000

* *DSL, Cable and Other may not add up to Total penetration due to rounding*⁴

3.2 Case Studies

Based on the technology analysis above we propose a taxonomy for IPTV services based on two dimensions: content linearity {from broadcasting to VoD}, and network integration {from public Internet to managed IP networks}. Additionally we use the colouring scheme from the value chain representations of Figures 2-3 to represent the role of the dominant player. The taxonomy translates well over to business models and to exemplify that we have selected three service providers from the Danish market that we will analyse through case studies.

⁴ Source: OECD in (Galik 2006)

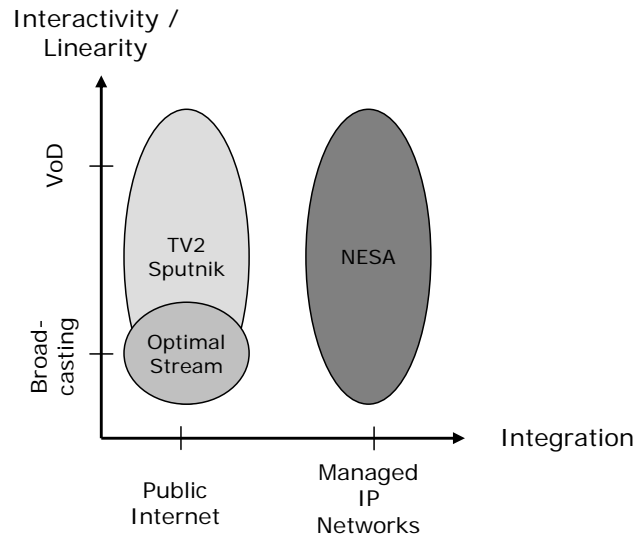

Figure 4: Graphical representation of two-dimensional taxonomy used for selecting case-studies in the Danish IPTV market.

3.2.1 Optimal Stream

Optimal Stream⁵ is an IPTV service provider, which delivers IPTV to Danish households over the public Internet. At the moment, a number of Danish and foreign TV channels are available on the platform. There is a variety of examples of implementation of IPTV and of bringing broadcast TV to the IP platforms on the Danish market, and the Optimal Stream example does not change the current concept of the delivery of TV in a multi-channel environment. Optimal Stream offers live broadcast over an IP platform and organises the content in different packages like a cable TV system. Optimal Stream uses the Internet backbone as the distribution platform for their service.

To be able to receive the TV channels one must have:

- A broadband connection of at least 2 Mbps
- An ISMA⁶ compatible MPEG-4 set-top box or an ISMA compatible MPEG-4 player
- A subscription

The service is accessible from <https://www.optimalstream.net/>, and the TV channels available on the platform are: Animal Planet, BBC World News, CNBC Europe,

⁵ Source: <https://www.optimalstream.net/>

⁶ ISMA (Internet Streaming Media Alliance) is an alliance of hardware manufacturers, software firms and service providers. The objective of ISMA is to create a common international standard for streaming, which can be deployed in a platform independent manner. According to ISMA, the goal of the alliance is ‘to accelerate the adoption and deployment of open standards for streaming rich media content such as video, audio, and associated data, over Internet protocols.’ For more information please refer to <http://www.isma.tv/>

Discovery Channel Europe, Discovery Civilisation, Discovery Science, Travel and Living – Discovery DR 1 & DR 2 (Danish Public Service), The UK Golf Channel, Horror Channel, NRK1 & NRK2 (Norwegian Public Service), Lokal-TV (Local TV in Copenhagen area), Pro Sieben (German movies and news), TV2 Danmark (Danish Public Service), TV Danmark 2, TV2 Norge, TV4 Sverige, and VIVA. The number of services is similar to the services available in the cable TV networks. The subscription cost is 99 DKK (about 15 US\$).

Two observations about the Optimal Stream service:

- The quality is not as good as the Danish cable TV services. The advantage compared to the cable TV services is, however, that the subscribers are not dependent on one infrastructure. The services can be accessed whenever one has access to a broadband network
- Even though the service is similar to cable TV, it is not subject to cable TV regulations

3.2.2 TV2 Sputnik

TV2 Sputnik⁷ is another example of an IPTV service provider that uses the public Internet for content distribution. It is offered by one of the public service broadcasters in Denmark. Contrary to Optimal Stream, TV2 Sputnik is not just copying the broadcast model from cable TV to the IP platform. There are two main radical differences in TV2 Sputnik's adaptation to the IP platform: 1) Sputnik uses the 'on demand' approach, i.e. the content is not a live transmission of TV2's different TV channels, and the users can select between various content from these programs in a 'time shifted' manner, and 2) TV2 as a content provider offering the services directly to the end users and does not go through a service or package/bouquet provider.

The first point illustrates the utilisation of the strong interactive component, utilizing the built in two-way transmission feature of IP platforms, and the second goes against the dominant paradigm introduced in the cable and satellite models and later adopted in different digital TV platforms, where the content provider goes through a service provider, which maintains Conditional Access etc. However, like Optimal Stream, the Internet is used as the distribution platform.

TV 2 Sputnik is organised in collaboration between TV 2 Danmark and Nordisk Film A/S (a subsidiary of Egmont). The collaboration between TV2 and Nordisk Film was settled in December 2004 and TV2 Sputnik was launched in April 2005.

TV2 Sputnik offers two different services: 'Sputnik TV' and 'Sputnik Film'. The first one is an 'on demand' version of regular TV channels and contains news, documentaries,

⁷ Source: www.tv2.dk

series, etc., and the second one is a VoD service, where one can choose between different movies. The film titles available in 'Sputnik Film' are both Danish and international, all provided by Nordisk Film.

The service is based on Windows Media Video 9 (WMV9) and can be accessed by computers or by TV through computers or dedicated boxes delivered by KISS technology. Regarding broadband connection, one needs a minimum connectivity of 512 Kbps down stream for 'Sputnik TV' and 1 Mbps for 'Sputnik Film'. Optimal quality can be obtained by having at least a 1 Mbps for 'Sputnik TV' and 2 Mbps broadband connection for 'Sputnik Film'.

With regards to the video streaming quality, 'Sputnik TV' transmits in 800 Kbps and 380 Kbps and 'Sputnik Film' in 1.3 Mbps and 800 Kbps. The so-called 'sure stream' technology is used, where the stream automatically adapts to the capacity available at the end user site and uses the most optimal streaming connection: The higher speed connectivity at the end user site, the better streaming quality.

To be able to access 'Sputnik TV', one must have a subscription:

- 20 DKK⁸ per 24 hours access
- 49 DKK per one month access
- 139 DKK per 3 months
- 269 DKK per half year
- 499 DKK per year

For 'Sputnik Film' one must typically pay between 20 - 45 DKK for a movie, and the subscription lasts 24 hours. With regard to 'Sputnik Film', it is required that one must live in Denmark to be able to use the service. Selected programs like TV2 news and weather forecast are available for free, however, with reduced quality - about 100 Kbps.

3.2.3 NESÅ

NESA A/S⁹ is an energy utility company operating in the vicinity of Copenhagen. The company has its core activities in electricity distribution and trade and is the biggest electricity provider in Denmark with 535,000 customers. For the past 15 years, the company has been deploying fibre cables to support its core activities, e.g. through an IP based control system for their electricity installations, and the company now owns more than 25,000 Km of fibres and more than 700 Km of fibre traces.

In 2002, the company diversified into the residential broadband market and started implementing and testing a FTTH network. In the end of 2004, the company had 800 homes actively participating in a commercial pilot project. The deployment strategy of the company is to lay down empty micro-duct-tubes with power cables for subsequent

⁸ 1€= 7.5 DKK

⁹ Source: www.nesa.dk and interview.

blowing of fibres. The company has already connected 20,000 homes with tubes and intends to lay tubes to 200,000 homes in the next 5-7 years.

According to NESAs there are several important synergies between electricity supply and fibre optic infrastructure supply: a) common network planning, b) common digging projects, c) common network control and monitoring, and d) common service organisation. The cost of the fibre cable itself is minor in relation to the ground work and as NESAs phrases it: "It should be illegal not to establish fibre connections to the household when a digging project is ongoing".

NESA provides an operator independent network, where different service providers can access the households through NESAs network. NESAs owns and controls and maintains the broadband network and physical infrastructure. Today there are four service providers competing on four service types (see following figure).

	Internet	VoIP	Video-on-demand	TV
CyberCity	X			
Dansk Bredbånd	X	X	X	X
J-net	X			
V2tel		X		

The customers pay a fixed monthly fee of €50 for access to the infrastructure and then buy services directly from service providers through a web portal.

Dansk Bredbånd is currently the only provider of TV in the NESAs network. They use IPTV and offer different cable TV like packages and VoD services. Dansk Bredbånd uses a cable TV like service provision system, organising the service in different packages. In this way, it is similar to Optimal Stream. However, the main difference between NESAs and Optimal Stream is that NESAs does not use the general Internet as the distribution platform. They use their own managed IP network which connects to Dansk Bredbånd's managed IP network.

The TV packages contain local, national and international channels targeted at broad audiences. There are also specific packages for people with specific interest.

The cost of TV packages are (the prices are incl. Internet access):

- Basic package (10 TV channels + a number of radio channels): 75 DKK per month
- Advanced package (FastTV) (46 TV channels + a number of radio channels): 245 DKK per month; this package includes the basic package

Additional packages:

- International Package (6 TV channels): 69 DKK per month.

- Canal+ (5 TV channels – film and sport): 219 DKK per month.
- Private Gold (24 hours' eroticism): 69 DKK per month.

Furthermore, Dansk Bredbånd offers VoD for between 15-39 DKK per month.

When introducing future services, NESAs does not encounter technical limitations but considers standardisation as a barrier to the development, especially in set-top boxes for IPTV.

3.3 IPTV market development

Three observations are important in the development of IPTV market: 1) IP platforms, especially broadband platforms, are becoming a competing infrastructure for delivering of TV services. Until now, terrestrial, satellite and cable network have been the main delivery platforms and the main development has been towards digitalisation. 2) IP platforms, due to the inherent interactive component, are changing 'broadcast' in a fundamental way from a broadcast service to an *on demand* service. 3) The content providers can bypass service providers and directly offer services to the end consumers.

Regarding the first aspect, a number of broadband providers simply copy the business model from the multi-channel platforms like cable TV and satellite TV and offer services in different packages: Basic package, optional package, premium package, etc. 'Heavy television viewers living in areas with no cable infrastructure, and this is quite a common case in countries like Italy, Spain and Greece, may look at IPTV as a platform for multichannel television services competing with digital satellite platforms and DTT platforms' (Galik M. 2006).

The broadband operator simply build up a head-end like cable TV, take feeds from different TV station, generate live stream, form different packages and send them to the consumers. The consumers must have IP set-top boxes that convert the IPTV to regular TV and send it to the TV. This model is used on many broadband platforms, mainly as a part of 'triple play' services, e.g., the NESAs case in this paper. The model is also used on the general Internet, e.g., the Optimal Stream case in this paper.

The second aspect, *on demand* transformation, is important because the characteristics of IP platforms are used to add value to broadcast services. If we look at the composition of TV programs, we can see that the majority of programs are not live and are distributed at certain times by the broadcasting station due to planning considerations. In IPTV provision, this type of content can be put on a server so that users can use them when they want. Of course, when the main value of a program is connected to the ability to receive it live, IPTV must use its capability to offer it as live stream. A good case for this development is TV2 Sputnik, but also the way broadcasters use the Internet by simply putting a great deal of programs on the Web so that end users can use them on demand, either on their computer, TV, PDA, iPod,

The third aspect, bypassing the service provider, is not a new thing. In traditional analogue terrestrial broadcasting and Free-To-Air satellite broadcasting, there is no service provider. The programs are sent to the transmitters (satellite or terrestrial) by the broadcasters and received by the users. The content aggregators or *bouquet* providers emerged in the era of multi-channel TV platforms like cable and satellite. To establish a business model, the service/bouquet providers form different packages of TV channels and sell them to the end users. On the IP platforms, it is possible to continue using this model, and as seen above this is done by several broadband providers. It is, however, also possible for the broadcaster to bypass this service provider function and sell the services directly to the users. This is done by TV2 Sputnik. It is interesting to follow this development and to see if this is a successful organisation of service provision. Definitely this creates an incentive mismatch/conflict between broadband providers and content providers; a broadband operator does not get any revenue out of the huge traffic generated when the end users directly connect to a service like TV2 Sputnik. Another important question is if it is optimal for the broadcasters to maintain consumer subscription, etc.

4 Regulation

IPTV is a clear materialization of the convergence process. The regulatory challenges related to the IPTV services are a subset of the general convergence process, where the borderline between media, telecom and Information Technologies vanishes at the technological level and result in new requirements to the general regulatory framework.

Traditionally the media, telecom and IT are regulated by different institutions, based on different principles/requirements. In Denmark at least three different ministries are in charge of regulation of IPTV services. In comparison, e.g., China: 'In China and the Chinese Taipei, TV and Telecommunications services have been regulated by different agencies and strictly separated. Both of them have temporarily put IPTV under the umbrella of cable after lengthy and heated debate'¹⁰.

Putting different requirements to IPTV services than for example cable TV services result in unsatisfactory competition situation between services, which are very much comparable. On the other hand putting different requirements on the IP platforms and cable TV platforms creates uneven competition situation between the platform providers. One example related to this is the 'must carry' rule that forces the cable TV operators to distribute Public Service or local terrestrial programs in their networks free of charge, where IP platforms are free for such regulations.

In Europe there is an agreement that the regulation of IPTV and other future audio/video services must be defined at the European level. Since 1989 the European broadcast has been regulated in the framework of TV Without Frontiers (TVWF) Directive. Since 2002 there have been massive efforts from the Commission side to expand the scope of the TVWF Directive to include new Audio/Video services. The aim of the expansion is to

¹⁰ Chun Lin and Huifei Lin 2006

create level playing field for competition in the audiovisual industry, however, the platform access issues are not part of this Directive.

4.1 TVWF Directive

TV Without Frontiers (TVWF) provides the legal framework for television broadcasting within the European Union (EU). It is intended to promote freedom of transmission in broadcasting by setting down minimum rules for regulation of the content of television broadcasts by member States. The rules are also intended to ensure that the interests of television viewers are fully and properly protected and to promote European and independent production. (Ofcom 2005)

The TVWF Directive was introduced in 1989 (89/552/EEC) and was last amended in 1997 (97/36/EC). The TVWF Directive deals with a number of general issues important for having an internal market in Europe and for easing the free movement of services and at the same time to ensure and maintain European production of TV programs. Some important components of the directive are summarized in the Ofcom report (Ofcom 2005):

- access to designated events of national importance on free television may be mandated by Member States (Article 3a)
- excluding news, special events, games, advertising and teletext, broadcasters should transmit more than 50% of EU works and more than 10% of works coming from independent producers (Articles 4 and 5)
- advertisements should be separately identified and surreptitious or subliminal advertising is banned (Article 10)
- there are limits on when and how frequently advertisements can be inserted in programmes with a minimum of 20 minutes between advertisements (Article 11)
- advertisements should not exceed 15% of daily transmission time or 20% of transmission time in any one hour (Article 18)
- the duration and frequency of teleshopping windows is restricted to 15 minutes and eight windows respectively (Article 18a)
- advertisements must not prejudice respect for human dignity; discriminate on grounds of race, sex, or nationality; or encourage behaviour prejudicial to health, safety or the protection of the environment (Article 12)
- advertisements for tobacco products and prescription drugs are banned (Articles 13 and 14)
- there are restrictions on advertisements for alcoholic beverages (Article 15) and to protect children (Article 16)
- there are restrictions on sponsorship with a ban on sponsorship by tobacco or drug companies, and a ban on sponsorship of news and current affairs programmes (Article 17)
- the content of sponsored television programmes must not be influenced by the sponsor and must not encourage the purchase or rental of the sponsor's or a third party's products. Sponsored programmes should be clearly identified as such (Article 17)

- broadcasters should not transmit programmes which might seriously affect the well being of children (Article 22)
- broadcasts should not contain any incitement to hatred on grounds of race, sex, religion or nationality (Article 22a)
- anyone defamed by a TV programme should have a right to reply (Article 23).

4.2 Extension of TVWF Directive

In May 2002, the Cultural and Audiovisual Affairs Council decided to review the TVWF Directive, ‘the key question in the review was whether the Directive should be extended to cover new audiovisual services, in the light of technological developments and changes’ (Ofcom 2005). This was further in connection to the European i2010’s requirement on the need for an integrated approach to the information society and the audiovisual media policies in the EU.

The main conclusion from the debate started in 2002 was that ‘keeping the “Television without Frontiers” Directive as it stands now would aggravate increasingly unjustifiable differences in regulatory treatment between the various forms of distributing identical or similar media content and that action at EU level was thus needed to enhance legal certainty in order to ensure the best possible conditions for the competitiveness of the sector. (EU 2005)

In fall 2005 a proposal for the Extension of the TVWF Directive was formed and published (COM(2005) 646 final). As stated in the document ‘The objective of this proposal is to ensure that on-demand audiovisual media services providers within the Member States can fully benefit from the internal market through the principle of regulation by the country of origin. This would enhance legal certainty overall for all audiovisual media service providers within the EU’.

A major step in the new proposal is the replacement of the ‘TV broadcast’ concept with the concept of ‘audiovisual media service’, which means ‘a service as defined by Articles 49 and 50 of the Treaty the principal purpose of which is the provision of moving images with or without sound, in order to inform, entertain or educate, to the general public by electronic communications networks within the meaning of Article 2(a) of Directive 2002/21/EC of the European Parliament and of the Council’ (EU 2006).

Furthermore a clear distinction between linear and non-linear services are introduced with the following definitions: ‘ ‘television broadcasting’ or ‘television broadcast’ mean a linear audiovisual media service where a media service provider decides upon the moment in time when a specific programme is transmitted and establishes the programme schedule; ‘broadcaster’ means provider of linear audiovisual media services; and ‘non-linear service’ means an audiovisual media service where the user decides upon the moment in time when a specific programme is transmitted on the basis of a choice of content selected by the media service provider;’ (EU 2006)

According to the proposal, the creation of “level playing field’ and technology neutrality have been the basis for the development of the new proposal: ‘Indeed, modern rules in the audiovisual policy field should not discriminate between and within different platforms delivering similar content and should create a level playing field for fair and enhanced competition between different operators, while enabling new services to flourish...The set of applicable rules shall no longer depend on the delivery platform but on the nature of a service. The future regulation will distinguish between linear audiovisual services or “broadcasting”, including IPTV, streaming or web-casting on one side, and non-linear services, such as “video-on-demand”- services, on the other side.’

According to (Ofcom 2005) the two tier set of rules developed in the extension discussions of the TVWF Directive will be formed such that the basic tier rules which address:

- Protection of minors and public order and respect for human dignity,
- Identification of advertisements,
- A ban on tobacco and prescription drug advertisements,
- Right of reply,
- Identification of the content provider,

will be applied to both linear and nonlinear type of services, while the detailed rules concerning:

- Quotas on EU content and independent production,
- Advertising frequency restrictions and limits on advertising minutes per hour,
- Restrictions on alcohol advertising,
- Restrictions on sponsorship,
- Access to events of national importance,

will only be applied to the linear services.

4.3 IPTV Regulation

Apart from the above mentioned regulatory aspects which concerns regulation of TV and audiovisual content, there are a number of other regulatory aspects which concerns the access issues of must carry, interoperability and the rights issues and the rights management.

The ‘must carry’ rule is applied to some infrastructures offering linear audiovisual content like the cable TV networks. Some broadband networks are capable of offering exactly the same services as cable TV and in reality they copy the business model of the cable TV, i.e., the organization of the content in different tiers (Basic, optional, premium, pay preview...). In long run it will be difficult to maintain different rules for different infrastructures, as it definitely contradicts with the technology neutrality regime and creates uneven competition conditions. There can, however, be other reasons for maintaining lighter regulation for certain period of time when it comes to the IP broadband

networks to promote new technologies and services. This type of ‘regulatory holidays’ are emerging in Scandinavia, e.g. by the Norwegian Post and Telecommunications Authority in dealing with VoIP¹¹

The interoperability is another key question. There are a number of different standards for IPTV provisions (like Microsoft or DVB based standards). These standards are not interoperable and therefore can create ‘lock in’ situation, where the consumer will have difficulties leaving a service provider, as this requires change of hardware and getting used to new user interfaces etc. The interoperability problems are well known from the digital TV market, where different systems for Conditional Access (CA) and Application program Interface (API) are available on the market. In digital TV some solutions to the problems were introduced partly through standardization and partly by requirements for interoperability on the set-top-boxes (Tadayoni 2000).

Another aspect relates to the rights issues of the content owners. The content owners are concerned about the IP platforms’ capabilities of redistribution of content. The technical solution to this problem is implementing DRM systems.

5 Conclusion

Development of IPTV is closely intervened with the development of residential broadband. While previously there existed a gap between the requirements of IPTV and the capabilities of access networks and services, today, this gap has been bridged through advancements in coding and transmission, Digital Rights Management etc. Despite a technological solution to most of the issues confronting IPTV, lack of an overall standardisation framework has diversified implementation efforts which to date are mostly built on proprietary solutions. With network access providers investing in new or upgraded infrastructure platform, they are likely to demand a larger share of the value chain, forcing service / content providers into revenue sharing cooperation through service differentiation.

After analysing the technology behind IPTV a taxonomy was developed for distinguishing between implementation variants based on two dimensions: content linearity {from broadcasting to VoD}, and network integration {from public Internet to managed IP networks}. The proposed taxonomy translates well over to business models applied in the Scandinavian market and to exemplify that we have selected three service providers from the Danish market that were analysed through case studies.

Penetration and development of broadband access is a major policy and business issue in many parts of the world, including Europe. Here different (and new) market players are taking part in the development of broadband using a variety of competitive and complementary technologies. TV and Video services will be major services in the broadband networks. We see two main models of deployment of TV over broadband: 1)

¹¹ In (Jensen, 2006) , Willy Jensen, General Director of the Norwegian Post and Telecommunications Authority describes commercial VoIP services which “ ... are subject to the same legal requirements as providers of traditional telephone services, but that temporary exemptions may be given from some of the obligations for an interim period”.

The traditional distributive model known from other multi channel distribution platforms like cable TV and satellite TV, and 2) A new model, where the TV broadcast evolves to a combination of “linear” and “non linear” / “on demand” provision in the IP networks with strong component of interactivity and with new business models, where the TV program provider directly accesses the end consumers and bypasses the “content aggregator”/ “Bouquet provider”.

Regulatory frame work of IPTV consists of a complex combination of traditional TV regulatory measures, access regulations, and regulation of resource organisation in the IP platforms. An important aspect is that the TV provided in the IP networks can be similar to the TV provided in any other platform. Here it is important that the same regulatory frame work is applied to both. Another aspect is that the TV / video services offered in the IP networks can have radically new characteristics based on the Interactivity component that is inherent in the IP platform. The development moves from ‘broadcast’ to ‘on demand’, from ‘push’ to ‘pull’, from somebody else decides the timing of consumption / ‘scheduling’ to end-consumer decides on the scheduling of consumption. These new characteristics may call for new regulatory framework. In Europe a distinction is made between ‘linear’ and ‘non linear’, services with the room for different regulatory measures.

Access and resource organisation issues are other aspects of the IPTV regulation. In the analogue TV a main question was creation of framework for access to transmission resources for TV transmission and the organisation of the content available in these resources (the TV networks). For example in Europe the ‘must carry’ rule forces the Cable TV operators to distribute public service and local TV programs in their networks. Complexity of access and resource issues was intensified by the emergence of digital broadcast; in the discussion of organisation Electronic Program Guide (EPG), interoperability/standardisation discussions of Application Program Interface (API) and Conditional Access (CA), new modes of access to the spectrum resources from the supply side, etc. In the IPTV the standardisation /interoperability aspect is intensified as there are a large variety of standards on the market and the access issues like ‘must carry’ are potential challenges. However, many regulators both when it comes to content and access / resource issues put a lighter regulatory frame work on these emerging technologies to create more optimal conditions for development and innovation.

6 References

R.J. Bates, Broadband Telecommunications Handbook, 2nd ed., McGraw-Hill, US, 2002

EU. On reviewing the interoperability of digital interactive television services pursuant to Communication COM(2004) 541 of 30 July 2004, Brussels, 02.02.06

EU, COM(2005) 646 final, Proposal for a directive of the European parliament and of the council amending council Directive 89/552/EEC, 2005

J.F. Fleury, IPTV: The Need for Standards, In proceedings of IBC 2005, Amsterdam, 2005

M. Gálik. IPTV on Fixed line telephone networks, In proceedings of the COST - A20 Conference, Delphi, Greece, 2006

R. Heron, N. Van Parijs, Evolutionary Pathways for the Broadband Access Network, Alcatel Telecommunications Review - 2nd Quarter 2003

D. Karyabwite. Victoria Falls presentation, February, 2004. Available on-line at: <http://www.itu.int/ITU-D/e-strategy/internet/Seminars/Zimbabwe/Victoria%20Falls.ppt>

Chun Liu, Huifei Lin. IPTV: Experiences of China and Chinese Taipei, PTC'06 Proceedings, 2006

MRG. 2006 IPTV Standards Survey Report — Summary, An independent MRG report commissioned by ISMA

Ofcom, Extension of the Television Without Frontiers Directive, An Impact Assessment, Final report for Ofcom, Indepen, Ovum and fathorn, 2005

B.M. Owen, Assigning Broadband Rights. Regulation, Vol. 27, No. 2, pp. 24-29, Summer 2004 Available at SSRN: <http://ssrn.com/abstract=568222>

B.Perkin. The Art of Overlaying Video Services on a BPON, Bechtel Telecommunication Technical Journal, Vol. 2, No. 2, 2004.

W. Simpson ed., Video-Over IP, Focal Press, Elsevier, UK, 2006

H. Stephansen. IP Video Contribution – How about when IP packets are lost, In proceedings of IBC 2005, Amsterdam, 2005

R Tadayoni: 'A comparative analysis of the access issues in digital broadcasting in Europe and USA', ITS 2000, Buenos Aires, July 2000

[online] April 2006. IPTV Focus Group (FG IPTV), URL: <http://www.itu.int/ITU-T/IPTV/index.phtml>

[online] April 2006. ITU given lead role in IPTV standardisation, URL: <http://www.itwire.com.au/content/view/3929/127/>