



All-optical 40 Gbit/s compact integrated interferometric wavelength converter

Jørgensen, Carsten; Danielsen, Søren Lykke; Hansen, Peter Bukhave; Stubkjær, Kristian; Schilling, M.; Daub, K.; Lach, E.; Laube, G.; Idler, W.; Wünnstel, K.

Published in:

Proc. of OFC'97, Optical Fiber communication Conference and Exhibition, OSA Technical Digest, Vol. 6

Link to article, DOI:

[10.1109/OFC.1997.719705](https://doi.org/10.1109/OFC.1997.719705)

Publication date:

1997

Document Version

Publisher's PDF, also known as Version of record

[Link back to DTU Orbit](#)

Citation (APA):

Jørgensen, C., Danielsen, S. L., Hansen, P. B., Stubkjær, K., Schilling, M., Daub, K., ... Wünnstel, K. (1997). All-optical 40 Gbit/s compact integrated interferometric wavelength converter. In Proc. of OFC'97, Optical Fiber communication Conference and Exhibition, OSA Technical Digest, Vol. 6 (pp. 94-95). Dallas, Texas, USA: IEEE. DOI: 10.1109/OFC.1997.719705

DTU Library

Technical Information Center of Denmark

General rights

Copyright and moral rights for the publications made accessible in the public portal are retained by the authors and/or other copyright owners and it is a condition of accessing publications that users recognise and abide by the legal requirements associated with these rights.

- Users may download and print one copy of any publication from the public portal for the purpose of private study or research.
- You may not further distribute the material or use it for any profit-making activity or commercial gain
- You may freely distribute the URL identifying the publication in the public portal

If you believe that this document breaches copyright please contact us providing details, and we will remove access to the work immediately and investigate your claim.

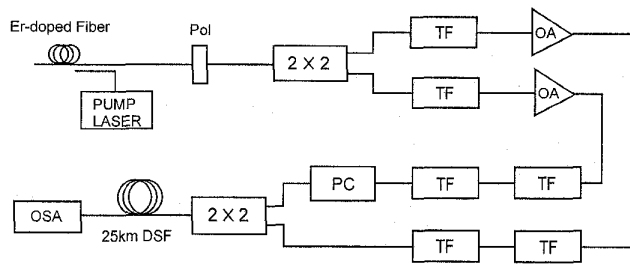

TuN7 Fig. 2. Experimental setup. Pol: polarizer, PC: polarization controller, TF: tunable filter, OA: optical amplifier.

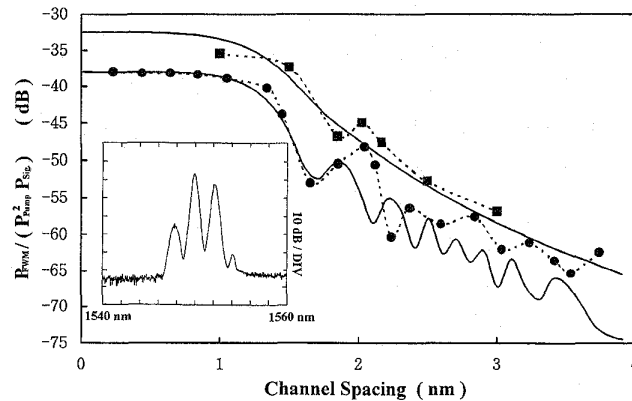

TuN7 Fig. 3. FWM efficiencies of incoherent light sources in comparison with coherent light sources. The solid lines are theoretically calculated curves. ■ represents the measured data for incoherent sources and ● represents the measured data for coherent sources. In this measurement, the signal channel was set at the dispersion-zero wavelength at 1.55 μm . The pump and signal powers were 0 dBm and 5 dBm, respectively. The inset shows an optical spectrum measured at the output of dispersion-shifted fiber with two incoherent input signals.

wavelength while the wavelength of pump channel was varied. The FWM power was measured using an optical spectrum analyzer and an optical power meter. The same experiment was repeated with two external cavity tunable lasers to make a comparison with coherent light sources.

Figure 3 shows the measured FWM power of coherent and incoherent light sources in comparison with theoretically calculated curves. The FWM power is normalized by the input signal powers, $P_1^2 P_2$. The results for the laser sources show good agreement with other papers.^{2,3} When two input signals were used, the incoherent light sources generate about 5 dB higher FWM efficiency than coherent sources. However, the FWM efficiency of the incoherent light source was similar to the coherent sources if three input signals were used, as expected. We also found that the bandwidth of an incoherent light becomes slightly broader after traversing the fiber due to FWM, even when only one light was launched into fiber. These results confirm that the incoherent light could be modeled as sum of numerous independent frequency components.

In summary, we investigated the FWM of incoherent lights in a dispersion-shifted fiber. The results show that, when two input signals were used, the FWM of incoherent sources is about 5 dB more efficient than that of coherent sources due to the degeneracy factor.

1. K.O. Hill, D.C. Johnson, B.S. Kawasaki, R.I. MacDonald, J. Appl. Phys. **49**, 5098–5106 (1978).
2. R.W. Tkach, A.R. Chraply, F. Forghieri, A.H. Gnauck, R.M. Derosier, IEEE J. Lightwave Technol. **13**, 841–849 (1995).

3. Kyo Inoue and Hiromu Toba, IEEE J. Lightwave Technol. **10**, 350–360 (1992).
4. J.S. Lee, Y.C. Chung, D.J. DiGiovanni, IEEE Photon. Technol. Lett. **5**, 1458–1461 (1993).
5. Joseph W. Goodman, *Statistical Optics*, (Wiley, New York).

TuO

4:30–6:30pm
Ballroom C2

Wavelength Conversion

Katherine Hall, MIT Lincoln Laboratory, President

TuO1

4:30pm

All-optical 40-Gbit/s compact integrated interferometric wavelength converter

C. Joergensen, S.L. Danielsen, P.B. Hansen, K.E. Stubkjaer, M. Schilling,* K. Daub,* E. Lach,* G. Laube,* W. Idler,* K. Wunstel,* Center for Broadband Telecommunications, Department of Electromagnetic Systems, Technical University of Denmark, Building 348, DK-2800 Lyngby, Denmark; E-mail: cj@emi.dtu.dk

Some of the most practical all-optical wavelength-conversion devices reported in the literature exploit the cross-gain (XGM) or cross-phase (XPM) modulation concept using semiconductor optical amplifiers (SOAs) alone or SOAs integrated into interferometric structures.^{1–5} Recently, 40 Gbit/s wavelength conversion using the very simple XGM principle in a speed-optimized SOA was demonstrated³ verifying the potentially high-speed operation associated with the relatively simple interband carrier recombination process. Here, an interferometric Michelson wavelength converter is presented that combines a speed-optimized SOA technology with the benefits of the integrated interferometer showing 40-Gbit/s wavelength conversion for the first time to our knowledge. The optimized wavelength converter demonstrates noninverted converted signals as well as converts to both shorter and longer wavelengths. Excellent results are achieved with ~10 dB extinction ratio and more than 25 dB signal-to-ASE (amplified spontaneous emission) ratio (1 nm) for the converted signals at 40 Gbit/s.

The monolithic integrated Michelson interferometer (MI) chip is realized using all-active multiple quantum well (MQW) based layer

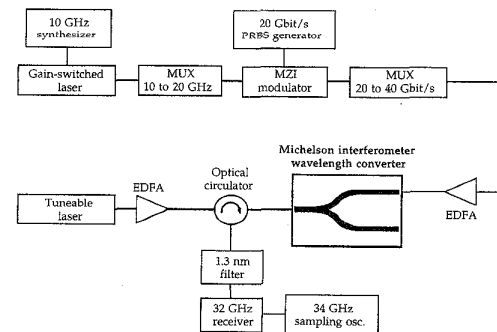

TuO1 Fig. 1. Experimental setup for investigation of the wavelength conversion performance of the Michelson interferometer at 40 Gbit/s.

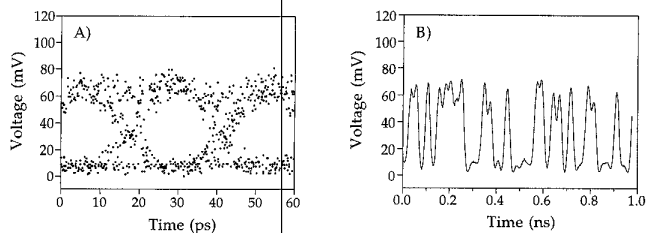

TuO1 Fig. 2. (A) Eye diagram and (B) waveform for 40-Gbit/s converted signal at 1562 nm. Signal-to-ASE ratio (in 1 nm) is 27 dB; signal input power (in the fiber): 8 dBm; cw power: 9 dBm.

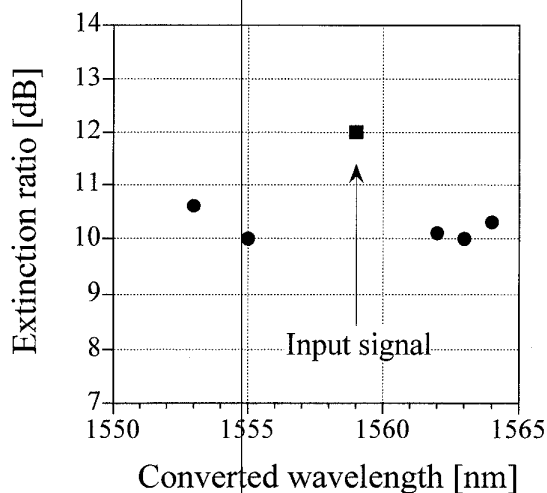

TuO1 Fig. 3. Extinction ratio of converted signals versus the converter output wavelength. Signal-to-ASE ratio for all converted signals is >25 dB (in 1 nm).

structures that result in a very simplified and compact device with a total length of only 1.3 mm. Importantly, the optimized MQW stack layer with the vertical layer stack containing a 10-well tensile-strained InGaAs/InGaAsP waveguide core results in a high differential gain and a high confinement factor enabling very high-speed operation.⁵

To assess the system performance of the MI converter at 40 Gbit/s a RZ input signal is generated by a gain-switched DFB laser emitting short pulses followed by passive delay-line multiplexers and a 20-Gbit/s Mach-Zehnder modulator (see Fig. 1). The signal is coupled directly to one of the interferometer arms at the highly reflective input port (right facet in Fig. 1). The resulting phase difference between the two interferometer branches alternates with the digital information of the input signal due to carrier depletion. Wavelength conversion is obtained as cw light at the desired output wavelength is coupled to the AR-coated input port of the coupler section (left facet in Fig. 1) and experiences the modulation of the MI transfer function. The cw light to the MI converter is provided by a tuneable laser source. At the converter output an optical circulator and a tuneable filter select the converted signal.

Figure 2 illustrates the fine conversion capability by a 40-Gbit/s converted eye diagram and a pulse trace for conversion from 1559–1562 nm (up conversion) with a signal input power to the converter of 8 dBm. High-speed all-optical wavelength conversion is demonstrated by the clear eye diagram showing ~ 10 dB extinction ratio. Additionally, it is important to note that the converted signal is not inverted compared to

the input and that the signal-to-ASE ratio is as high as 27 dB in 10-nm bandwidth.

The wavelength sensitivity is analyzed in Fig. 3 that gives the extinction ratio for the 40-Gbit/s converted signals versus the converter output wavelength. Impressive performance for both up and down conversion is obtained with ~ 10 -dB extinction ratio and >25 dB signal-to-ASE ratio (1 nm) for all wavelengths.

This work is partially supported by the European ACTS project AC-043 (KEOPS).

*Alcatel Telecom Research Division, Stuttgart, Alcatel SEL AG, Dept. ZFZ/WO, Lorenzstr. 10, D-70435 Stuttgart, Germany

1. J.M. Wiesenfeld *et al.*, Electron. Lett. **30**, 720–721 (1994).
2. X. Pan *et al.*, IEEE Photon. Technol. Lett. **7**, 995–997 (1995).
3. S.L. Danielsen *et al.*, in *Optical Fiber Communication Conference*, Vol. 2 of 1996 OSA Technical Digest Series (Optical Society of America, Washington, D.C., 1996), postdeadline paper 12.
4. M. Schilling *et al.*, in *Optical Fiber Communication Conference*, Vol. 2, 1996 OSA Technical Digest Series (Optical Society of America, Washington, D.C., 1996), pp. 122–124.
5. T. Durhuus *et al.*, IEEE J. Lightwave Technol. **14**, (1996).

TuO2

4:45pm

Transmission enhancement by deployment of interferometric wavelength converters within all-optical cross connects

H.N. Poulsen, B. Mikkelsen, K.E. Stubkjaer, *Center for Broadband Telecommunication, Department of Electromagnetic Systems, Technical University of Denmark, DK-2800 Lyngby, Denmark; E-mail: hnp@emi.dtu.dk*

Wavelength-division multiplexing (WDM) networks are expected to utilize all-optical cross connects (OXCN) for signal routing. Because a signal path is likely to contain a number of OXCNs, their cascability is essential. Furthermore, because wavelength converters in the OXCNs improve traffic performance and ease network management,¹ their cascability, in particular, is important. Using interferometric wavelength converters (IWCs) we have previously demonstrated experimentally a cascade of 10 converters at 10 Gbit/s with <2 -dB penalty.² In this paper we analyze the cascability limitations of OXCNs deploying IWCs.

The wavelength converters used in the experiments and in this analysis are interferometric wavelength converters, where semiconductor optical amplifiers (SOAs) are used as optically controlled phase shifters in a Michelson configuration.^{3,4} Converters based on this principle have the capability of pulse reshaping due to their sinusoidal transferfunction and small chirp.⁵

Importantly, when cascading nonlinear devices such as IWCs, the resulting transfer function is not the product of the individual IWC transfer functions. Here we show by detailed modeling that IWCs are cascable in large numbers (>30) at 10 Gbit/s and their reshaping capability enhances the possible transmission distance when interconnected by nondispersion-shifted (NDS) fiber. The modeling shows excellent agreement with experiments.⁵

In networks where the OXCNs are interconnected by dispersion-compensated fiber (zero accumulated dispersion between OXCNs), pulse distortion along the signal path arises during conversion. The effect of this pulse distortion is seen in Fig. 1, where the penalty for a