



## **A 2GHz, 17% tuning range quadrature CMOS VCO with high figure-of-merit and 0.6° phase error**

**Andreani, Pietro**

*Published in:*

Proceedings of the 28th European Solid-State Circuits Conference, 2002. ESSCIRC 2002.

*Publication date:*  
2002

*Document Version*  
Publisher's PDF, also known as Version of record

[Link back to DTU Orbit](#)

*Citation (APA):*

Andreani, P. (2002). A 2GHz, 17% tuning range quadrature CMOS VCO with high figure-of-merit and 0.6° phase error. In Proceedings of the 28th European Solid-State Circuits Conference, 2002. ESSCIRC 2002. IEEE.

## **DTU Library** Technical Information Center of Denmark

---

### **General rights**

Copyright and moral rights for the publications made accessible in the public portal are retained by the authors and/or other copyright owners and it is a condition of accessing publications that users recognise and abide by the legal requirements associated with these rights.

- Users may download and print one copy of any publication from the public portal for the purpose of private study or research.
- You may not further distribute the material or use it for any profit-making activity or commercial gain
- You may freely distribute the URL identifying the publication in the public portal

If you believe that this document breaches copyright please contact us providing details, and we will remove access to the work immediately and investigate your claim.

## A 2 GHz, 17% Tuning Range Quadrature CMOS VCO with High Figure-of-Merit and 0.6° Phase Error

Pietro Andreani  
Center for Physical Electronics  
Ørsted·DTU  
Technical University of Denmark  
DK-4800 Kgs. Lyngby, Denmark  
pa@oersted.dtu.dk

### Abstract

*This paper presents a quadrature VCO implemented in a standard 0.35 μm CMOS process. The VCO draws 16 mA from a 1.3 V power supply, can be tuned between 1.91 GHz and 2.27 GHz, and displays a phase noise of -140 dBc/Hz or less at 3 MHz offset frequency from the carrier, for a minimum phase-noise figure-of-merit of 184 dB. The maximum departure from quadrature between the VCO phases is 0.6°.*

### 1. Introduction

The theory and practice of monolithic quadrature voltage-controlled oscillator (QVCO) design has recently made significant progresses. The original QVCO [1] based on the cross-coupling of two differential LC-tank VCOs, with the coupling transistors  $M_{cpl}$  placed in parallel with the switch transistors  $M_{sw}$  (Fig. 1(a), where varactors have been omitted for readability, and all identical components have been named only once), was known to have a poor phase-noise behavior (although recent results [2] seem to contradict the previous experience; this issue will be clarified in the next section). This QVCO design will be referred to as the parallel QVCO (P-QVCO). Two modification of the P-QVCO have recently appeared in the literature. In the first case, phase shifters have been introduced between cascaded LC-resonators [3], allowing each resonator to be optimally driven at zero-degree phase shift [4]. The second approach consists in cross-coupling the two differential VCOs in the QVCO by placing  $M_{cpl}$  in series with  $M_{sw}$  [5], rather than in parallel (Fig. 1(b)). This choice is motivated by the fact that  $M_{cpl}$  in the P-QVCO is responsible for a large contribution to the phase noise, and connecting  $M_{cpl}$  in series with  $M_{sw}$ , in a cascode-like fashion, should greatly reduce the noise from the cascode device. This is indeed confirmed by simulations. Since in this case  $M_{cpl}$  is placed on top of  $M_{sw}$ , we will refer to this design as the top-series QVCO (TS-QVCO).

This paper presents an alternative way of achieving a series connection between  $M_{cpl}$  and  $M_{sw}$ , this time with

$M_{cpl}$  placed at the bottom of  $M_{sw}$ . This is the bottom-series QVCO (BS-QVCO, Fig. 1(c)). Simulations show that the BS-QVCO has a higher phase-noise figure-of-merit (FoM) than the P-QVCO when both BS-QVCO and P-QVCO display the same phase error; further, both simulations and measurements show that the BS-QVCO has a higher phase-noise FoM, but also a higher phase error, than the TS-QVCO.

### 2. Comparing different QVCOs

The issue of how two different QVCOs can be compared in a fair and meaningful way is less trivial than it might seem at first sight, since the two qualifying data for a QVCO, phase noise and phase error, are in general not independent of each other. This is especially evident in the case of the P-QVCO, where both phase noise and phase error are strong functions of  $\alpha$ , defined as the ratio of the width  $W_{cpl}$  of transistor  $M_{cpl}$  to the width  $W_{sw}$  of transistor  $M_{sw}$  (assuming that both transistors have the same length):

$$\alpha = \frac{W_{cpl}}{W_{sw}}. \quad (1)$$

To see how the phase error varies with  $\alpha$ , the single-sideband (SSB) upconversion circuit [1] [5] in Fig. 2 has been used, so that the overall phase/amplitude errors between the phases, very difficult to measure directly in a reliable way, are translated into the ratio of the wanted upconverted band, to the unwanted, image band (to be referred to as Image Band Rejection, IBR). In the case of the P-QVCO, simulations show that a mismatch of 0.1% between the two LC-tanks results in an IBR of 70 dB for  $\alpha = 1$ , which drops to 60 dB for  $\alpha = 1/2$ , and to 49 dB for  $\alpha = 1/3$ . Clearly, the phase error gets quickly larger when the coupling between the two VCOs in the P-QVCO is weakened by decreasing  $\alpha$ . On the other hand, it is easy to check that the phase noise, too, greatly decreases with a decreasing  $\alpha$ . Thus, it is straightforward to improve the phase-noise performance of the P-QVCO at the expense of its phase-error performance. This is the case for the already mentioned P-QVCO presented by Tiebout

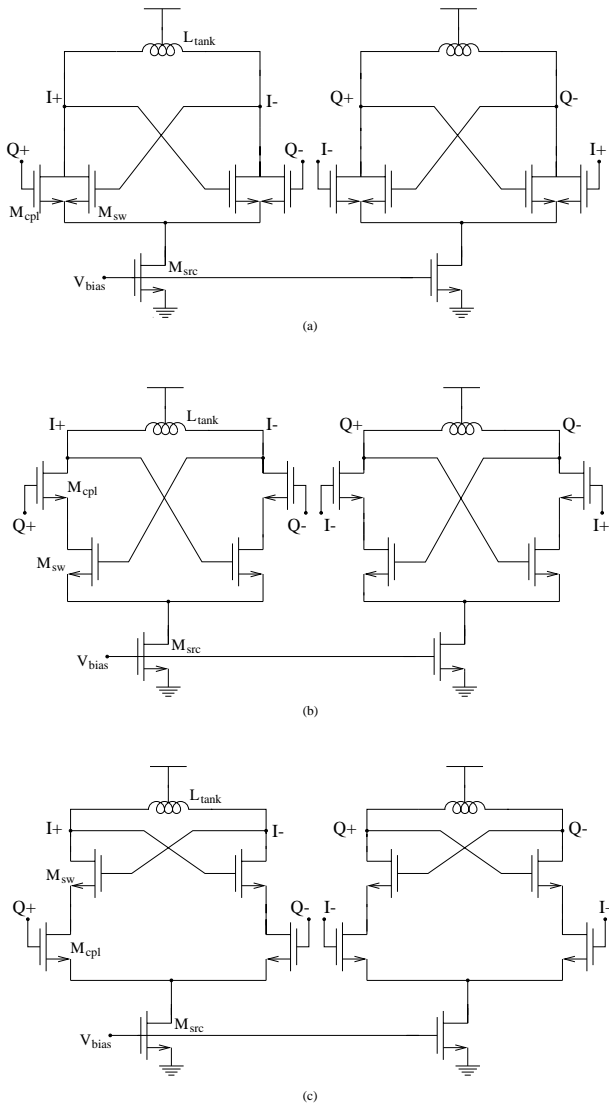

Figure 1. Schematic views of the a) parallel QVCO [1]; b) top-series QVCO [5]; c) bottom-series QVCO (this work).

[2], where a very high phase-noise FoM, the highest to date for QVCOs, was achieved by choosing  $\alpha = 1/3$ .

Since we have seen that phase noise and phase error are in general not orthogonal (and can be traded for each other in the P-QVCO), it is not enough to compare only the phase-noise FoM between different QVCOs. If possible, the phase-noise FoM should be compared when the same level of component mismatch causes the same phase error. This is certainly possible when comparing the P-QVCO and the BS-QVCO (or the TS-QVCO), since we have seen that the phase error in the P-QVCO can be tuned by changing  $\alpha$ . In the case of the series-QVCOs, on the contrary, the phase error is almost independent of  $\alpha$  for all reasonable values for  $\alpha$ . This means that, while we can choose the value for  $\alpha$  which minimizes the phase noise, the phase error cannot be improved by allowing a higher phase noise. In this case, the phase error acts more like a design constant (dependent of course on the actual amount

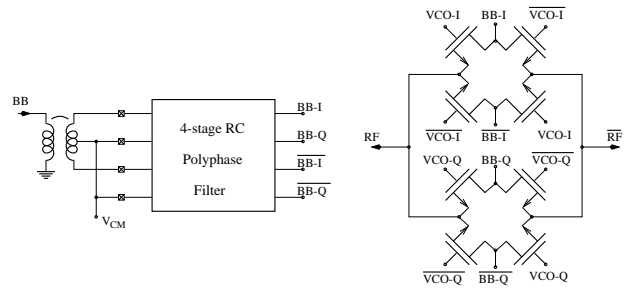

Figure 2. Block schematic of the image rejection architecture (QVCO not shown).

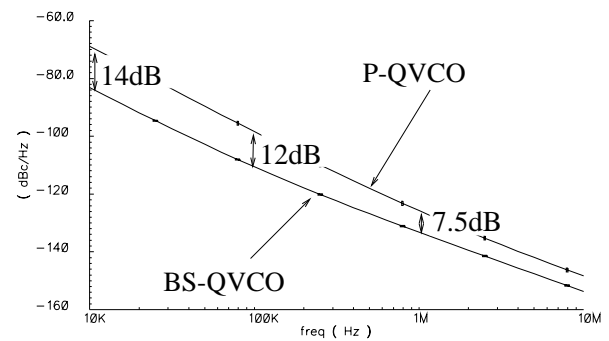

Figure 3. Fair phase-noise comparison between BS-QVCO and P-QVCO.

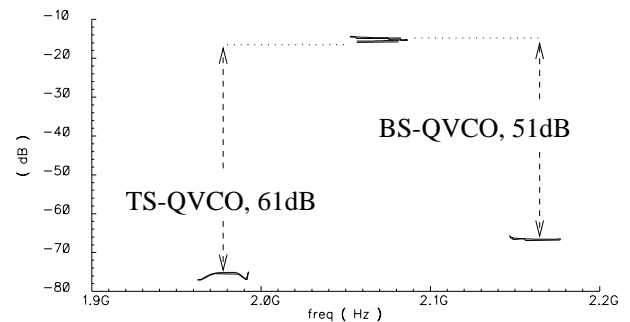

Figure 4. IBR for TS-QVCO and BS-QVCO.

of mismatch between ideally identical components), once the QVCO architecture has been selected. In the case of the BS-QVCO, assuming again a 0.1% mismatch between the LC-tanks, the achievable IBR is 51 dB, that is, approximately the same IBR displayed by the P-QVCO when  $\alpha = 1/3$ . If we now compare the phase noise displayed by the P-QVCO and the BS-QVCO (Fig. 3; varactors were removed in these simulations, so that the resulting phase noise is due to the oscillator topology alone), when both QVCOs have the same IBR, center frequency, and power consumption, there will be no doubt that the BS-QVCO does outperform the P-QVCO.

**BS-QVCO versus TS-QVCO.** The two series-QVCOs present different phase-noise and phase-error characteristics. IBR simulations, performed again in presence of a 0.1% mismatch between the LC-tanks, show that the IBR for the TS-QVCO is as high as 61 dB, which

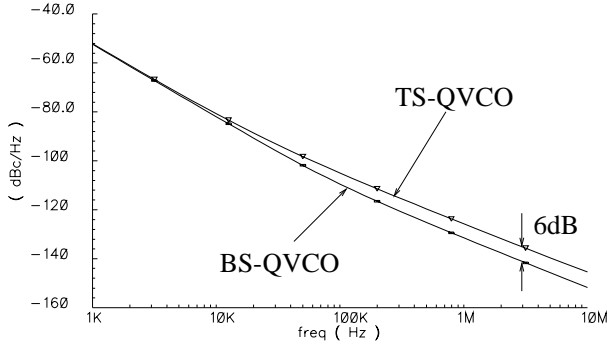

Figure 5. Phase-noise comparison between TS-QVCO and BS-QVCO.

Table 1. Dimensions and values for BS-QVCO and mixer components.

Transistors	
$M_{cpl}$	$400\mu\text{m} \times 0.35\mu\text{m}$
$M_{sw}$	$800\mu\text{m} \times 0.35\mu\text{m}$
$M_{varactor}$	$1200\mu\text{m} \times 0.35\mu\text{m}$
$M_{src}$	$2000\mu\text{m} \times 1.0\mu\text{m}$
$M_{mixer}$	$100\mu\text{m} \times 0.6\mu\text{m}$
Reactors	
$L_{tank}$	$\approx 2.3\text{ nH}$
Q of the LC-tank	$\approx 6$ at 2.0 GHz

is 10 dB higher than the IBR value obtained for the BS-QVCO (Fig. 4). At the same time, phase-noise simulations performed for the same center frequency and power consumption yield a considerably lower phase noise for the BS-QVCO, especially at higher offset frequencies (Fig. 5; even in this case all varactors were removed). It should be added that both IBR and phase-noise data are somewhat dependent on the Q of the LC-tanks.

### 3. Measurement results

The BS-QVCO has been designed in a standard  $0.35\mu\text{m}$  CMOS process with only three metal layers of thickness less than  $1\mu\text{m}$  each. MOS devices working in accumulation/depletion were used as varactors. Table 1 shows dimensions and values for the various components in the BS-QVCO and in the mixer used in the SSB upconverter. The BS-QVCO makes use of the same LC-tank layout that was adopted for the TS-QVCO presented in [5], in order to make a comparison as robust as possible, although it should be recognized that such a layout is clearly suboptimal, due to the very long interconnections between the two inductors, which introduce significant additional resistive losses (Fig. 6). As a consequence, the estimated Q at 2 GHz is approximately six, while it was eight when the same tank was used in a non-quadrature VCO [6]. All measurements have been performed with a power supply as low as 1.3 V, for a current consumption of 16 mA. The QVCO could be tuned from 1.91 GHz to 2.27 GHz, for a tuning range of

17%. The phase noise at 3 MHz offset frequency from the carrier was  $-140\text{ dBc/Hz}$  or lower across the tuning range (Fig. 7). Fig. 8 shows the phase-noise plot for the highest oscillation frequency. The FoM for the QVCO is calculated according to the commonly adopted formula

$$FoM = 10 \log \left( \left( \frac{f_c}{\Delta f} \right)^2 \frac{1}{L(\Delta f) P} \right), \quad (2)$$

where  $f_c$  is the oscillation frequency,  $\Delta f$  is the offset frequency,  $L(\Delta f)$  is the phase noise at  $\Delta f$ , and  $P$  is the power consumption in mW. Using the data in Fig. 7, the minimum value for the FoM across the tuning range is 184 dB, which is no less than 6 dB higher than the minimum FoM displayed by the TS-QVCO [5] (approximately 1 dB can be accounted for by the fact that the tuning range for the TS-QVCO was shifted some 200 MHz down in frequency, which resulted in a slightly lower LC-tank Q at the lowest oscillation frequencies). It is worth emphasizing that, contrary to common practice, it is the *minimum* FoM that truly matters.

Possibly even more striking is the comparison between the FoM for the BS-QVCO and that for the non-quadrature VCO presented in [6], which covered approximately the same frequency range, and whose LC-tank had a Q of eight at 2 GHz. This VCO has a minimum FoM of 183 dB, that is, 1 dB *lower* than the minimum FoM for the BS-QVCO. This is even more remarkable considering that the VCO in [6] made use of two noise reduction techniques, the on-chip noise filter [7] and the off-chip inductive degeneration of the tail transistor [6], which greatly enhanced its FoM. For the BS-QVCO it has been checked that the noise filter (implemented in a second, otherwise identical QVCO design) does not lead to an increase of the minimum FoM, while inductive degeneration increases it by 1 dB, too modest an improvement to grant the use of an external component. It is worth noting that the minimum FoM for the BS-QVCO is approximately 2.5 dB higher than that for the QVCO in [3], which was built in a much more advanced CMOS process (this comparison is based on the usual definition of phase noise, and not on the "quadrature" phase noise defined in [3]). As a last phase-noise comparison, the P-QVCO in [2] displays a minimum FoM 1 dB higher than the minimum FoM for the BS-QVCO; yet, this very good phase-noise behavior is most likely obtained at the expense of the phase error, as explained in the previous paragraph (the phase error reported in [2] is indeed very large, but was obtained through unreliable off-chip measurements).

As previously explained, the IBR was measured with the SSB upconverter in Fig. 2, and the IBR data are of course comprehensive not only of the mismatches in the QVCO, but also of those in the mixers and in the 4-stage RC polyphase filter used to generate the quadrature baseband signals. In all five samples the IBR is 50 dB or higher at the lower oscillation frequencies, and decreases with increasing oscillation frequencies, possibly indicating that varactor mismatches are the dominant cause for

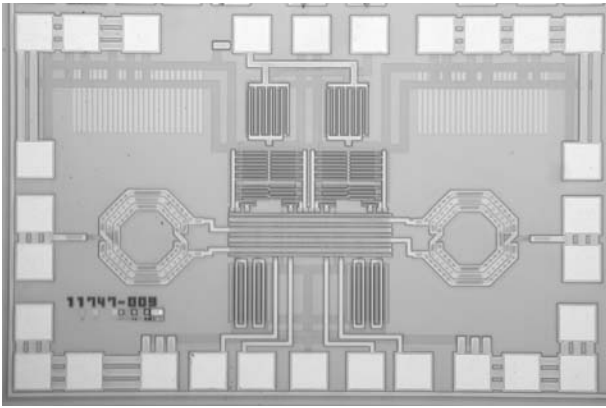

Figure 6. Die photograph of the BS-QVCO (1.4 mm×0.9 mm).

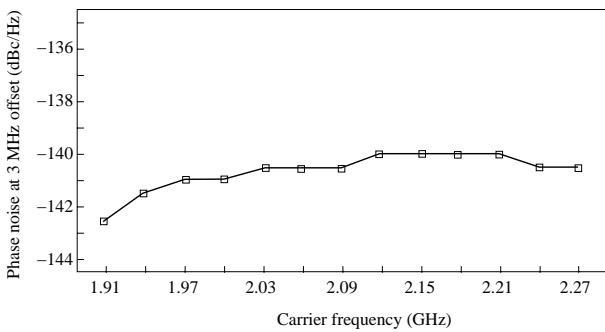

Figure 7. Phase noise for the BS-QVCO at 3 MHz offset frequency.

the phase error. Fig. 9 shows the minimum IBR (43 dB) measured for these samples. Assuming that the IBR is entirely caused by a deviation from quadrature of otherwise ideal sinusoidal outputs, simulations for the upconverter indicate that an IBR of 43 dB is equivalent to a phase error of approximately  $0.6^\circ$  between the I and Q phases. As could be expected from the results of the IBR simulations, this phase error is larger than the  $0.25^\circ$  measured for the TS-QVCO [5].

#### 4. Conclusions

A new CMOS QVCO, the BS-QVCO, has been presented. Compared to the well-known P-QVCO, the BS-QVCO displays a higher phase-noise FoM in presence of the same phase error. Further, the BS-QVCO has a higher phase-noise FoM than the TS-QVCO (yet another QVCO architecture), at the expense of a higher phase error.

#### 5. Acknowledgments

The author would like to thank Prof. R. Castello at the Dept. of Electronics, University of Pavia, Italy, and I. Bietti of STMicroelectronics, Pavia, Italy, for valuable discussions on technical matters.

[1] A. Rofougaran, J. Rael, M. Rofougaran, and A. Abidi. "A 900MHz CMOS LC-Oscillator with Quadrature Outputs". In *Proc. ISSCC 1996*, pp. 392–393, February 1996.

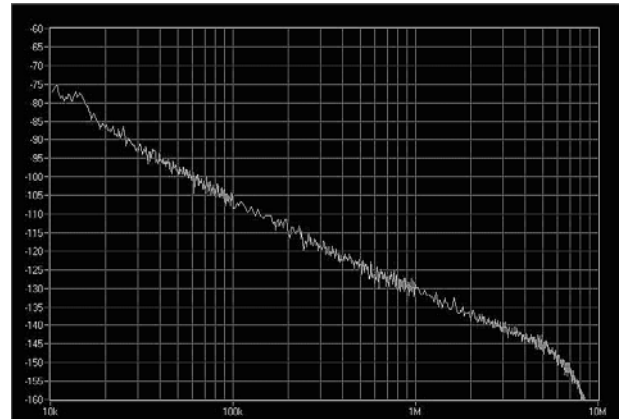

Figure 8. Phase noise for the BS-QVCO at 2.27 GHz oscillation frequency.

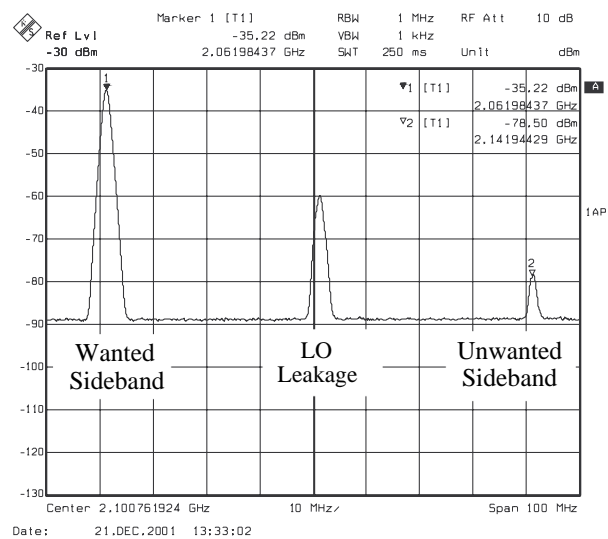

Figure 9. Upconverted baseband signals and LO leakage at 2.1 GHz carrier frequency (IBR = 43 dB, minimum IBR value across the tuning range).

[2] M. Tiebout. "Low-Power Low-Phase-Noise Differentially Tuned Quadrature VCO Design in Standard CMOS". *IEEE JSSC*, Vol. 36, NO. 7, pp. 1018–1024, July 2001.

[3] P. Vancorenland and M. Steyaert. "A 1.57 GHz Fully integrated Very Low Phase Noise Quadrature VCO". In *Proc. 2001 Symposium on VLSI Circuits*, pp. 111–114, June 2001.

[4] P. van de Ven, J. van der Tang, D. Kasperkovitz, and A. van Roermund. "An optimally coupled 5 GHz quadrature LC oscillator". In *Proc. 2001 Symposium on VLSI Circuits*, pp. 115–118, June 2001.

[5] P. Andreani. "A Low-Phase-Noise, Low-Phase-Error 1.8 GHz Quadrature CMOS VCO". In *Proc. ISSCC 2002*, pp. 290–291, February 2002.

[6] P. Andreani and H. Sjöland. "Tail Current Noise Suppression in RF CMOS VCOs". *IEEE JSSC*, Vol. 37, NO. 3, pp. 342–348, March 2002.

[7] E. Hegazi, H. Sjöland, and A. Abidi. "A Filtering Technique to Lower LC Oscillator Phase Noise". *IEEE JSSC*, Vol. 36, NO. 12, pp. 1921–1930, December 2001.