



## Photonic crystal fibers used in a multi-wavelength source and as transmission fiber in a WDM system

**Andersen, Peter Andreas; Zsigri, Beata; Peucheret, Christophe; Jeppesen, Palle; Hansen, K. P.; Nielsen, M. D.**

*Published in:*  
Technical Digest Conference on Lasers and Electro-Optics 2004

*Link to article, DOI:*  
[10.1109/CLEO.2004.1360635](https://doi.org/10.1109/CLEO.2004.1360635)

*Publication date:*  
2004

*Document Version*  
Publisher's PDF, also known as Version of record

[Link back to DTU Orbit](#)

*Citation (APA):*  
Andersen, P. A., Zsigri, B., Peucheret, C., Jeppesen, P., Hansen, K. P., & Nielsen, M. D. (2004). Photonic crystal fibers used in a multi-wavelength source and as transmission fiber in a WDM system. In Technical Digest Conference on Lasers and Electro-Optics 2004 (Vol. 2, pp. 7-8). IEEE. DOI: 10.1109/CLEO.2004.1360635

## DTU Library

Technical Information Center of Denmark

---

### General rights

Copyright and moral rights for the publications made accessible in the public portal are retained by the authors and/or other copyright owners and it is a condition of accessing publications that users recognise and abide by the legal requirements associated with these rights.

- Users may download and print one copy of any publication from the public portal for the purpose of private study or research.
- You may not further distribute the material or use it for any profit-making activity or commercial gain
- You may freely distribute the URL identifying the publication in the public portal

If you believe that this document breaches copyright please contact us providing details, and we will remove access to the work immediately and investigate your claim.

# Photonic Crystal Fibers used in a Multi-Wavelength Source and as Transmission Fiber in a WDM System

Peter Andreas Andersen, Beáta Zsigri, Christophe Peucheret and Palle Jeppesen  
 Research Center COM, Technical University of Denmark, DTU, Building 345V, DK-2800 Kgs. Lyngby, Denmark  
 Phone: (+45) 45 25 66 06 Fax: (+45) 45 93 65 81  
[paa@com.dtu.dk](mailto:paa@com.dtu.dk)

Kim P. Hansen and Martin Dybendal Nielsen  
 Crystal Fibre A/S Blokken 84, DK-3460 Birkerød, Denmark  
 Phone: (+45) 43 48 28 00 Fax: (+45) 43 48 28 01

**Abstract:** We present a WDM system based entirely on photonic crystal fibers. It includes a novel dispersion flattened highly nonlinear PCF to generate supercontinuum used in a multiwavelength pulse source and a 5.6 km transmission PCF.

© 2004 Optical Society of America

OCIS codes: (060.2330) Fiber optics communications; (060.2360) Fiber optics links and subsystems.

## 1. Introduction

Recent experiments have demonstrated the potential of photonic crystal fibers (PCF) for signal processing applications [1], and more recently as transmission fiber [2]. The PCF technology allows design of both highly nonlinear fibers for signal processing, as well as low-loss transmission fibers [3]. In this paper, we combine the two types of fibers and present a WDM system entirely based on PCFs. We use supercontinuum (SC) generation [4, 5] in a novel highly nonlinear PCF (HNL-PCF) to realize a multi-wavelength pulse source and transmit the  $5 \times 10$  Gbit/s WDM signal over 5.6 km transmission PCF.

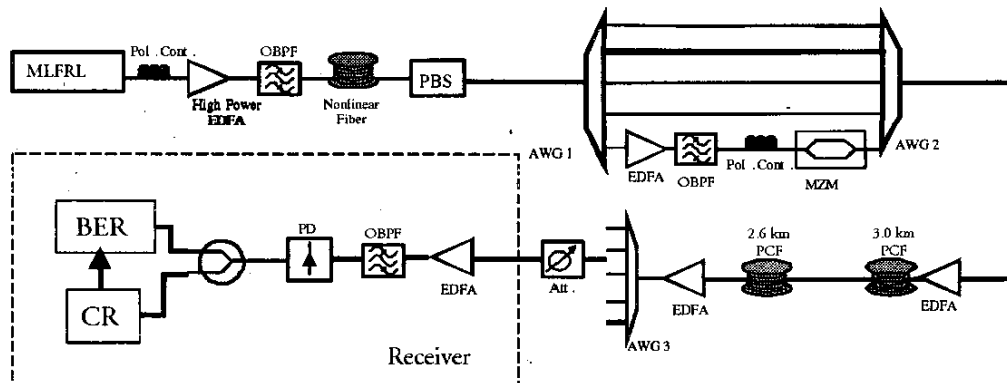

Fig. 1. Experimental setup. OBPF: optical bandpass filter, PBS: polarization beam splitter, AWG: arrayed waveguide grating, EDFA: Erbium doped fiber amplifier, MZM: Mach Zehnder modulator, PD: photodiode, CR: clock recovery and BER: bit error rate test-set.

## 2. Experiment

The experimental setup is shown in Fig. 1. A pulse train is generated by a mode-locked fiber ring laser (MLFRL) with repetition rate of 10 GHz at the wavelength of 1554.5 nm, before being amplified by an erbium doped fiber amplifier (EDFA) delivering 27 dBm average power. The HNL-PCF is 100 m long and has a nonlinear coefficient of  $11.2 \text{ W}^{-1}\text{km}^{-1}$  [6]. It exhibits a dispersion flattened profile with a dispersion slope of  $1 \times 10^{-3} \text{ ps/nm}^2/\text{km}$ . The pulses have a FWHM of  $\sim 2.9$  ps before entering the HNL-PCF. The SC generated in the HNL-PCF is then sliced into 5 channels by an arrayed waveguide grating (AWG) with 200 GHz channel spacing (channel 1 at 1552.52 nm and channel 5 at 1558.96 nm). The channels were modulated one by one with a 10 Gbit/s PRBS signal ( $2^{31}-1$ ) giving the WDM worst case scenario with one modulated channel and the adjacent channels all transmitting strings of one bits. The sliced pulses are Gaussian shaped with a FWHM of  $\sim 2.8$  ps after modulation and are therefore suited for higher bit rates. The modulated signal and pulse trains are then multiplexed together in an AWG and

transmitted over 5.6 km of transmission PCF with 1.7 dB/km loss, 32 ps/nm/km dispersion at 1550-nm and 0.067 ps/nm<sup>2</sup>/km dispersion slope. After transmission, the 5 channels are demultiplexed before being input to a pre-amplified receiver.

### 3. Results

The bit-error-rate (BER) curves have been measured after the modulator (back-to-back) and after transmission over 5.6 km PCF. Fig. 2 shows the best and worst-case BER curves as well as all the eye diagrams after transmission. It is seen from Fig. 2 that the penalty ranges between 0 and 3.4 dB for the best and worst channels, respectively. The eye-diagrams after transmission (measured in a 50 GHz bandwidth) are seen to be open.

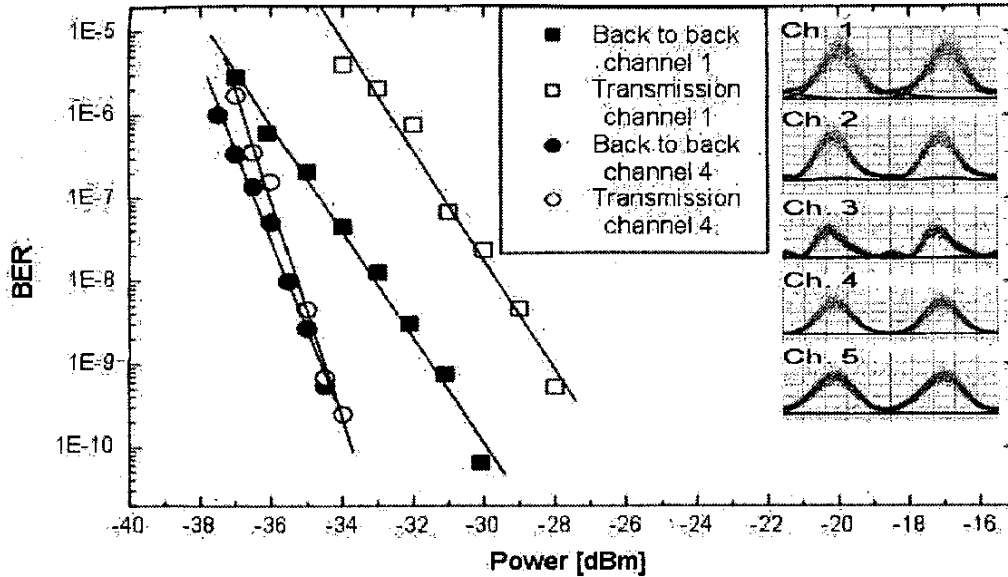

Fig. 2. BER curves for best and worst case channels with received eye-diagrams for all 5 channels.

The poorer performance of channel 1 is believed to be due to the lower power of the supercontinuum spectrum in this wavelength range. However no significant eye degradation was observed for this channel apart from extra noise. Therefore all 5 channels have been transmitted successfully through the PCF link.

As a conclusion, we have successfully demonstrated WDM signal generation using supercontinuum generation in a novel dispersion flattened highly nonlinear PCF, followed by transmission over 5.6 km PCF.

### References

- [1] K. Hansen, J. Folkenberg, A. Petersson and A. Bjarklev, "Properties of nonlinear photonic crystal fibers for telecommunication applications", OFC'03, paper FI2, vol. 2, pp. 694-696.
- [2] B. Zsigri, C. Peucheret, M. D. Nielsen and P. Jeppesen, "Transmission over 5.6 km large effective area and low-loss (1.7 dB/km) photonic crystal fibre", Electron. Lett. **39**, 796-798 (2003).
- [3] K. Tajima, J. Zhou, K. Kurokawa and K. Nakajima, "Low water peak photonic crystal fibres", ECOC'03, post-deadline paper Th4.1.6, vol. 6, pp. 42-43.
- [4] Z. Yusoff, P. Teh, P. Petropoulos, K. Furusawa, W. Belardi, T. Monro and D. Richardson, "24 channels  $\times$  10 GHz spectrally sliced pulse source based on spectral broadening in a highly nonlinear holey fiber", OFC'03, paper FH3, vol. 2, pp. 687-689.
- [5] T. Yamamoto, H. Kubota, S. Kawanishi, M. Tanaka and S. Yamaguchi, "Supercontinuum generation at 1.55  $\mu$ m in a dispersion-flattened polarization-maintaining photonic crystal fiber", Opt. Express **11**, 1537-1540 (2003).
- [6] K. P. Hansen "Dispersion flattened hybrid-core nonlinear photonic crystal fiber" Opt. Express **11**, 1503-1509 (2003).