

Adaptive Backstepping Control of Lightweight Tower Wind Turbine

Galeazzi, Roberto; Borup, Kasper Trolle; Niemann, Hans Henrik; Poulsen, Niels Kjølstad; Caponetti, Fabio

Published in:

Proceedings of the 2015 American Control Conference (ACC 2015)

Link to article, DOI:

[10.1109/ACC.2015.7171802](https://doi.org/10.1109/ACC.2015.7171802)

Publication date:

2015

Document Version

Peer reviewed version

[Link back to DTU Orbit](#)

Citation (APA):

Galeazzi, R., Borup, K. T., Niemann, H. H., Poulsen, N. K., & Caponetti, F. (2015). Adaptive Backstepping Control of Lightweight Tower Wind Turbine. In Proceedings of the 2015 American Control Conference (ACC 2015) (pp. 3058-3065). IEEE. (American Control Conference). DOI: 10.1109/ACC.2015.7171802

DTU Library

Technical Information Center of Denmark

General rights

Copyright and moral rights for the publications made accessible in the public portal are retained by the authors and/or other copyright owners and it is a condition of accessing publications that users recognise and abide by the legal requirements associated with these rights.

- Users may download and print one copy of any publication from the public portal for the purpose of private study or research.
- You may not further distribute the material or use it for any profit-making activity or commercial gain
- You may freely distribute the URL identifying the publication in the public portal

If you believe that this document breaches copyright please contact us providing details, and we will remove access to the work immediately and investigate your claim.

Adaptive Backstepping Control of Lightweight Tower Wind Turbine

Roberto Galeazzi¹, Kasper T. Borup², Henrik Niemann¹, Niels K. Poulsen³ and Fabio Caponetti⁴

Abstract—This paper investigates the feasibility of operating a wind turbine with lightweight tower in the full load region exploiting an adaptive nonlinear controller that allows the turbine to dynamically lean against the wind while maintaining nominal power output. The use of lightweight structures for towers and foundations would greatly reduce the construction cost of the wind turbine, however extra features ought to be included in the control system architecture to avoid tower collapse. An adaptive backstepping collective pitch controller is proposed for tower point tracking control, i.e. to modify the angular deflection of the tower with respect to the vertical axis in response to variations in wind speed. The controller is shown to guarantee asymptotic tracking of the reference trajectory. The performance of the control system is evaluated through deterministic and stochastic simulations including an extreme wind gust event, and the feasibility of stabilizing the tower position while maintaining the rated power output is shown.

I. INTRODUCTION

The turbine tower accounts for a significant portion of the total cost of a wind turbine. Tegen et al [21] showed that for a 1.5 MW land-based wind turbine (rotor diameter of 82.5 m; tower height of 80 m) the tower accounts for 16% of the total turbine installed capital cost. Considering that the current trend in the wind industry is “higher and bigger” to enhance the capability of harvesting stronger winds, it can be foreseen that the tower cost will hardly reduce. The large cost stems from the fact that a tower needs to withstand bending moments from the thrust acting on the turbine rotor.

The thrust force may be balanced through gravitational forces by e.g. mounting the tower on a hinge-like structure and having the thrust being controlled in such a way that a dynamic equilibrium is reached with the turbine leaning towards the wind. This would leave only compression forces to be handled by the tower, allowing for a very light structure.

In offshore applications the hinge effect could be obtained by a floating foundation operated by hydraulic and/or electro-mechanical means. This would stabilize the platform in low wind speeds for service. If no other means of control are introduced, e.g. at the hinging point, then the challenge is to design a control system that keeps the turbine balanced

during operation by adjusting the pitch angle and/or the rotor speed. This can be achieved only when the rotor is rotating; therefore means for fastening the turbine on the hinge in very low winds should also be available. The paper addresses the tower stabilization problem for a wind turbine operating in the full load region, i.e. for wind speeds larger than the rated wind speed. The hinged wind turbine concept shares challenges with floating wind turbines, see e.g. [18] and [22].

For a long period of time control theory has found a challenging application in wind turbines. The methods most frequently used in industry are based on classical design [15], but more advanced techniques have also attracted attention in research during the last decade [14]. Regulation of wind turbines in the partial load and in the full load regions has been addressed through gain scheduling [1], adaptive control [10], robust control and μ -Synthesis design [6], [16], [17], and model predictive control [8] just to mention a few.

Interesting examples of nonlinear control methods for the partial load region can be found in e.g. [3], [5], and [19]. In the full load region the aerodynamic torque and thrust lack of explicit representations and this represents a challenge for the application of methods such as e.g. feedback linearization and backstepping. An attempt to overcome these issues by an adaptive nonlinear controller was presented in [20].

A. Main Contribution

The main contribution of the paper is the design of an adaptive backstepping collective pitch controller that guarantees that the moments due to the thrust force and the gravitational force are dynamically balanced, hence ensuring that the wind turbine is kept upright. The designed controller achieves the control objective by ensuring the asymptotic tracking of the reference tower angular displacement. Adaptivity is included to overcome the uncertain knowledge of the thrust coefficient C_T . By means of the extended matching/tuning functions design procedure [13] a just-parametrized adaptive controller is obtained.

To demonstrate that balancing of the tower against the wind and electrical power regulation can be simultaneously achieved, a PI generator torque controller is also designed through Lyapunov stability theory for the regulation of the electrical power to the rated value.

B. Organization of the Paper

The paper is structured as follows: Section II presents the aerodynamic and mechanical model of the wind turbine with lightweight tower; Section III formulates the control problem and presents the main result in Proposition 1; Section IV provides a performance evaluation of the proposed control

¹Roberto Galeazzi and Henrik Niemann are with the Automation and Control Group, DTU Electrical Engineering, Technical University of Denmark, Kgs. Lyngby, Denmark {rg,hnn}@elektro.dtu.dk

²Kasper Trolle Borup is with the Centre for Autonomous Marine Operations and Systems, Norwegian University of Science and Technology, Trondheim, Norway, and with the Automation and Control Group, DTU Electrical Engineering, Technical University of Denmark, Kgs. Lyngby, Denmark kasper.borup@itk.ntnu.no

³Niels K. Poulsen is with the Section of Dynamical Systems, DTU Compute, Technical University of Denmark, Kgs. Lyngby, Denmark nkpo@dtu.dk

⁴Fabio Caponetti is with Vestas Wind Systems, Aarhus, Denmark facap@vestas.com

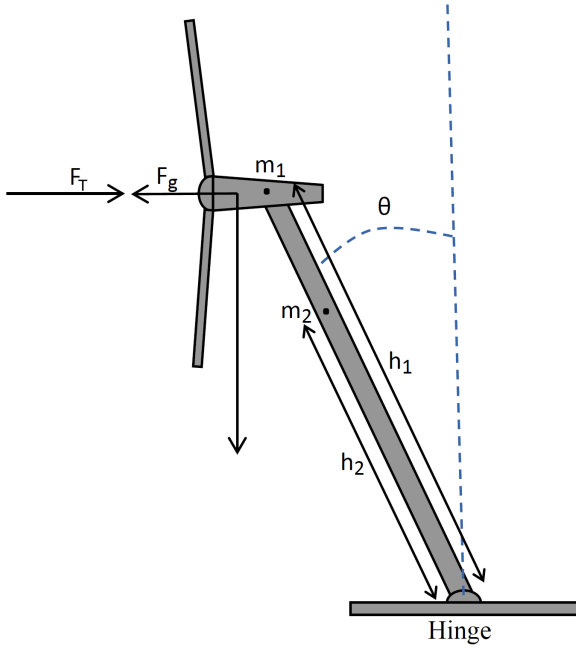

Fig. 1. Schematic of the horizontal axis wind turbine mounted on top of a lightweight tower, which is modeled as an inverted pendulum with a hinge mechanism at the pivot.

architecture through deterministic and stochastic simulations; last, Section V draws some conclusions.

II. DYNAMICAL MODEL OF LIGHTWEIGHT TOWER WIND TURBINE

The wind energy conversion system (WECS) considered in this paper is a horizontal axis, three bladed variable speed-variable pitch wind turbine with lightweight tower. The extreme flexibility of the tower is modeled as a hinge mechanism at the bottom of the tower that allows rotation of the WECS around the y -axis of an inertial fixed frame. Therefore, the wind turbine can be seen as an inverted pendulum (the lightweight tower) atop of which the nacelle and the rotor are placed. A schematic of the analyzed system is shown in Fig. 1.

The dynamics of the wind turbine with lightweight tower is analyzed in the following. First a brief overview of the relevant aerodynamics is given in order to introduce the forces and moments acting on the rotor disc and on the tower. Then a mechanical model is set up, which accounts for the rotor dynamics and the tower dynamics.

A. Aerodynamics

The available power P_a in the wind passing through a rotor disc area $A = \pi R^2$ with wind speed U_∞ is

$$P_a = \frac{1}{2} \rho_a \pi R^2 U_\infty^3 \quad (1)$$

where ρ_a is the air density, and R is the blade tip radius. Only a fraction of the available wind power can be converted to rotor power P_r , and the ratio between the two is given by

the non-dimensional power coefficient $C_P(\lambda, \beta)$

$$P_r = C_P(\lambda, \beta) P_a, \quad (2)$$

where λ is the tip-speed ratio and β is the blades' pitch angle. The tip-speed-ratio λ is defined as

$$\lambda \triangleq \frac{\omega_r R}{U_\infty}, \quad (3)$$

where ω_r is the rotor angular velocity.

The power coefficient $C_P(\lambda, \beta)$ has a theoretical maximum achievable value $C_{P, \text{Betz}} = 0.593$, known as the Betz limit; however modern commercial wind turbines achieve 75% – 80% of the Betz limit [1], [4].

The passage of the wind through the rotor disc produces two effects. The first effect is the aerodynamics torque T_a , which determines the rotational motion of the rotor and produces useful work. The aerodynamic torque is given by

$$T_a = \frac{1}{2} \rho_a \pi R^2 C_P(\lambda, \beta) \frac{U_\infty^2}{\omega_r}. \quad (4)$$

The second effect is the thrust force that must be withstood by the rotor, tower and foundations. The thrust force is given by

$$F_T = \frac{1}{2} \rho_a \pi R^2 C_T(\lambda, \beta) U_\infty^2 \quad (5)$$

where $C_T(\lambda, \beta)$ is the non-dimensional thrust coefficient.

The aerodynamic coefficients C_P and C_T are complex nonlinear functions of the blades' pitch angle β and the tip-speed-ratio λ , and their shape is strongly influenced by the specific geometrical characteristics of the blades. Due to their complex shape and variability closed form formulas are hardly available, and it is then customary to use look-up tables to model the aerodynamic effects.

Remark. In (4) and (5) the wind speed U_∞ should be replaced by the wind speed relative to the rotor $U_{\text{rel}} = U_\infty - U_{\text{tower}}$ since the nacelle is not stationary in the considered scenario. However, the correction factor due to the linear velocity of the nacelle in the fore-aft direction is expected to be small as result of small variations of the angular deflection of the tower; hence we assume that $U_{\text{rel}} \approx U_\infty$.

B. Lightweight Tower Wind Turbine Dynamics

The dynamics of the wind turbine with flexible tower consists of the dynamics of the rotor subject to the aerodynamic torque and to the generator torque, and the dynamics of the flexible structure (rotor-nacelle-tower) subject to the thrust force and to the gravitational force.

Rotor Dynamics The modeling of the rotor dynamics varies with regard to assumptions of stiffness in the shafts of the drive-train, damping, inertia assessment and efficiency. The adopted model is the traditional one-mass model since for the main control objective at hand the inclusion of torsional effects present e.g. in the two-mass drive-train model does not add relevant dynamical effects/phenomena.

The rotor dynamics is derived applying Newton's Second Law for rotation, which links the angular acceleration of the

rotor to the aerodynamic torque T_a and generator torque T_g , that is

$$\begin{aligned} J\dot{\omega}_r &= T_a - N_g T_g \\ &= \frac{1}{2}\rho_a \pi R^2 C_p(\lambda, \beta) \frac{U_\infty^3}{\omega_r} - N_g T_g \end{aligned} \quad (6)$$

where J accounts for both the rotor and generator inertia, and N_g is the gear ratio.

Tower Dynamics A simplified model of the flexible structure can be derived by approximating the wind turbine as an inverted pendulum fastened to the ground through a hinge mechanism. The masses of the wind turbine are lumped into two different points: the first mass m_1 is located at the nacelle height h_1 , while the second one, m_2 , is located at a certain height h_2 of the tower.

Let θ_t be the angular displacement of the tower with respect to the vertical (as displayed in Fig. 1), then applying again Newton's Second Law for rotation and assuming the damping of the hinge to be negligible, the rotation around the y-axis is given by

$$\begin{aligned} I_t \ddot{\theta}_t &= \tau_1 - \tau_2 \\ &= (h_1 m_1 + h_2 m_2) g \sin \theta_t - h_1 F_T \cos \theta_t, \end{aligned} \quad (7)$$

where $I_t = M_t h_1^2$ is the tower inertia of the structure with $M_t = m_1 + m_2$ is the total mass; τ_1 and τ_2 the moments due to the gravitational force F_g and the thrust force F_T , respectively.

Note that the normal to the rotor plane is always considered parallel to ground, and (7) is valid for $\theta_t \in [0; \sin^{-1}(R/h_1)]$, where $\sin^{-1}(R/h_1)$ is found by trigonometric relations as the point where the rotor blades touch the ground.

Pitch Blade Dynamics The pitch blade actuator dynamics is modeled as a first order system

$$\dot{\beta} = -\frac{1}{\tau_\beta}(\beta - \beta_{\text{ref}}), \quad (8)$$

where $\tau_\beta > 0$ is the actuator time constant, and β_{ref} is the control input.

Generator Torque Dynamics Assuming that an inner loop is closed by a local controller actuating the generator current, the generator torque dynamics is then modeled as a first order system (9), where $\tau_g > 0$ is the generator time constant, and $T_{g,\text{ref}}$ is the control input

$$\dot{T}_g = -\frac{1}{\tau_g}(T_g - T_{g,\text{ref}}). \quad (9)$$

C. State Space Model

Let $\mathbf{x} = [\theta_t, \omega_t, \omega_r, \beta, T_g]^T$ be the state vector where $\omega_t = \dot{\theta}_t$, and $\mathbf{u} = [\beta_{\text{ref}}, T_{g,\text{ref}}]^T$ be control input vector. Then the state space model of the whole system reads

$$\dot{\mathbf{x}} = \begin{bmatrix} \dot{\theta}_t \\ \dot{\omega}_t \\ \dot{\omega}_r \\ \dot{\beta} \\ \dot{T}_g \end{bmatrix} = \begin{bmatrix} \omega_t \\ c_1 \sin \theta_t - c_2 C_T(\omega_r, \beta, U_\infty) U_\infty^2 \cos \theta_t \\ c_3 C_p(\omega_r, \beta, U_\infty) \frac{U_\infty^3}{\omega_r} - c_4 T_g \\ -\frac{1}{\tau_\beta}(\beta - \beta_{\text{ref}}) \\ -\frac{1}{\tau_g}(T_g - T_{g,\text{ref}}) \end{bmatrix} \quad (10)$$

where the following constants have been defined to ease derivations, $c_1 \triangleq (m_1 h_1 + m_2 h_2) g / I_t$, $c_2 \triangleq \rho_a \pi R^2 h_1 / 2 I_t$, $c_3 \triangleq \rho_a \pi R^2 / 2 J$ and $c_4 \triangleq N_g / J$.

The state is assumed to be fully accessible and additional measurements of the wind speed U_∞ and the produced electrical power P_e are available, hence the output vector is $\mathbf{y} = [\mathbf{x}^T, U_\infty, P_e]^T$.

III. LIGHTWEIGHT TOWER POINT TRACKING CONTROL

This section presents the main contribution, namely Proposition 1, where an adaptive backstepping collective pitch controller is designed to stabilize the wind turbine against the wind. This is achieved through the asymptotic tracking of the tower inclination trajectory $\theta_{t,\text{ref}}$. The adopted design method is based on tuning functions [13, Chapter 4], which allows designing an adaptive controller of minimum order, that is the number of parameter estimates is equal to the number of unknown parameters.

The secondary control objective is to regulate the electrical power P_e at the rated value \bar{P}_e . This is fulfilled by means of a PI generator torque controller designed through Lyapunov stability theory.

Problem Statement (Tower Point Tracking Control). Consider the wind turbine with lightweight tower (10) operating in the full load region, i.e. the wind speed $U_\infty \geq \bar{U}$, where \bar{U} is the rated wind speed. Let $\theta_{t,\text{ref}}(t) \triangleq \theta_{t,\text{ref}}(U_\infty, \beta, \lambda) \in \mathcal{C}^3$ the reference trajectory for the tower deflection θ_t , which guarantees that the moments due to the gravitational force F_g is in dynamical balance with the moment due to the thrust force F_T . The control problem is to achieve asymptotic tracking of the tower reference trajectory, i.e. $\lim_{t \rightarrow \infty} \theta_t = \theta_{t,\text{ref}}$, while regulating the electrical power P_e to the rated value \bar{P}_e .

The wind turbine tower deflection is controlled through the reference pitch angle β_{ref} of the rotor blades, and the power output is regulated utilizing the reference generator torque $T_{g,\text{ref}}$.

For the first controller a time-varying, linear in the parameters approximation of the thrust coefficient C_T is proposed

$$C_T(\lambda, \beta) \approx \alpha_0(t) + \alpha_1(t)\lambda + \alpha_2(t)\beta \quad (11)$$

where $\alpha_j(t)$ $j = 1, 2, 3$ is assumed to be a slowly varying function of time such that $\dot{\alpha}_j \approx 0$. This approach has already been successfully adopted in [20] to approximate the power coefficient for the design of an adaptive individual pitch controller.

A. Adaptive Backstepping Tower Deflection Control

Let $\Theta_{\text{ref}} = [\theta_{t,\text{ref}}, \omega_{t,\text{ref}}, \dot{\omega}_{t,\text{ref}}, \ddot{\omega}_{t,\text{ref}}]^T$ be the reference trajectory vector including position, velocity, acceleration, and jerk. Further, let $\tilde{\theta}_t = \theta_{t,\text{ref}} - \theta_t$ and $\tilde{\omega}_t = \omega_{t,\text{ref}} - \omega_t$ be the position and velocity tracking errors. Then using (11) the

tower deflection dynamics in (10) can be rewritten as

$$\dot{\tilde{\theta}}_t = \tilde{\omega}_t \quad (12)$$

$$\begin{aligned} \dot{\tilde{\omega}}_t &= \dot{\omega}_{t,\text{ref}} - c_1 \sin \theta_t \\ &+ c_2(\alpha_0 + \alpha_1 \lambda + \alpha_2 \beta) U_\infty^2 \cos \theta_t. \end{aligned} \quad (13)$$

The control objective is to design an adaptive collective pitch feedback control law that stabilizes the origin of the system (12)-(13). Instead of operating directly on $\tilde{\theta}_t$ and $\tilde{\omega}_t$ we define the manifold $s = \tilde{\omega}_t + \Lambda \tilde{\theta}_t = 0$, $\Lambda > 0$, where the tracking error dynamics has to be constrained by the control law. On the manifold the error dynamics is governed by $\dot{\tilde{\theta}}_t = -\Lambda \tilde{\theta}_t$, which guarantees that the origin is locally exponentially stable and the convergence rate depends on Λ .

In the new variable s the tracking error dynamics (12)-(13) together with the pitch actuator dynamics read

$$\begin{aligned} \dot{s} &= \dot{\tilde{\omega}}_t - \Lambda \tilde{\omega}_t \\ &= \chi(\xi, t) \beta + v^T(\xi, t) \varphi + \psi(\xi, \mathbf{e}, t) \end{aligned} \quad (14)$$

$$\dot{\beta} = -\frac{1}{\tau_\beta} (\beta - \beta_{\text{ref}}) \quad (15)$$

where $\xi = [\theta_t, \omega_t]^T$, $\mathbf{e} = [\tilde{\theta}_t, \tilde{\omega}_t]^T$, $\chi(\xi, t) = c_2 \alpha_2 U_\infty^2 \cos \theta_t$ is the uncertain input gain, $v(\xi, t) = [U_\infty^2 \cos \theta_t, \omega_t U_\infty \cos \theta_t]^T$ is the regressor, $\varphi = [\tilde{\alpha}_0, \tilde{\alpha}_1]^T = [c_2 \alpha_0, c_2 R \alpha_1]^T$ is the unknown parameter vector, and $\psi(\xi, \mathbf{e}, t) = \dot{\omega}_{t,\text{ref}} - c_1 \sin \theta_t - \Lambda \tilde{\omega}_t$ is a known nonlinear function.

It is also assumed that the sign of $\chi(\xi, t)$ is known and constant for all $t > 0$; for the specific region the turbine works on it is negative.

Proposition 1. Let $\mathbf{z} = [z_1, \beta - \Phi(z_1, \xi, \mathbf{e}, \hat{\rho}, t)]^T$ be the vector of error variables, where

$$\Phi(z_1, \xi, \mathbf{e}, \hat{\rho}, t) \triangleq -\hat{\rho} \underbrace{(\kappa_1 z_1 + v^T(\xi, t) \hat{\varphi} + \psi(\xi, \mathbf{e}, t))}_{\phi}$$

The collective pitch control law

$$\begin{aligned} \beta_{\text{ref}} \triangleq & \beta + \tau_\beta \left[-\kappa_2 z_2 - \hat{\chi} \left(z_1 - \frac{\partial \Phi}{\partial z_1} \beta - \frac{\partial \Phi}{\partial \tilde{\omega}_t} \beta \right) \right. \\ & + \left(\frac{\partial \Phi}{\partial z_1} + \frac{\partial \Phi}{\partial \tilde{\omega}_t} \right) (v^T \hat{\varphi} + \psi) - \frac{\partial \Phi}{\partial \tilde{\omega}_t} \Lambda \tilde{\omega}_t \\ & \left. + \frac{\partial \Phi}{\partial \theta_t} \omega_t + \frac{\partial \Phi}{\partial \hat{\varphi}} \dot{\hat{\varphi}} + \frac{\partial \Phi}{\partial \hat{\rho}} \dot{\hat{\rho}} - \hat{\rho} (\hat{\sigma}^T \hat{\varphi} + \dot{\omega}_{t,\text{ref}}) \right] \end{aligned} \quad (16)$$

with the adaptation laws

$$\dot{\hat{\varphi}} = \Gamma_1 \left[\pi + \left(\frac{\partial \Phi}{\partial z_1} + \frac{\partial \Phi}{\partial \tilde{\omega}_t} \right) v z_2 \right] \quad (17)$$

$$\dot{\hat{\chi}} = \gamma_1 \left(z_1 z_2 - \frac{\partial \Phi}{\partial z_1} \beta z_2 \right) \quad (18)$$

$$\dot{\hat{\rho}} = -\gamma_2 \text{sgn}(\chi) \phi z_1 \quad (19)$$

$$\dot{\hat{\sigma}} = \Gamma_2 \hat{\rho} \hat{\varphi} z_2 \quad (20)$$

globally stabilizes the origin of the \mathbf{z} -dynamics, and guarantees that $\theta_t \rightarrow \theta_{\text{ref}}$ as $t \rightarrow \infty$. The gains κ_1 , κ_2 , γ_1 , γ_2 are greater than zero, and the matrices Γ_1 , Γ_2 are positive definite and symmetric.

Proof. First an adaptive feedback stabilizing control law is designed for the dynamics of z_1 , which equals the s -dynamics (14), by using the collective blade pitch angle β as virtual control input. Stabilization is achieved through a control Lyapunov function (CLF) by designing a stabilizing function Φ and a tuning function π . Then the system is augmented with the pitch actuator dynamics by means of the error variable z_2 . Stabilization of the z_2 -dynamics through a second CLF is achieved through the design of the update laws for the parameter estimates $\hat{\varphi}$, $\hat{\chi}$, $\hat{\rho}$, $\hat{\sigma}$, and the adaptive feedback control β_{ref} .

Step 1 Introducing the error state \mathbf{z} the dynamics (14) is rewritten as

$$\dot{z}_1 = \chi(z_2 + \Phi + v^T \varphi + \psi). \quad (21)$$

The control objective in this step is to design the stabilizing function $\Phi(\mathbf{z}, \xi, \mathbf{e}, \hat{\rho}, t)$ such that the origin of (21) is stable.

Consider the control Lyapunov function candidate

$$V_1(z_1, \tilde{\varphi}) = \frac{1}{2} z_1^2 + \tilde{\varphi}^T \Gamma_1^{-1} \tilde{\varphi} > 0, \quad \forall (z_1, \tilde{\varphi}) \neq \mathbf{0}, \quad (22)$$

where $\tilde{\varphi} = \varphi - \hat{\varphi}$ is the parameter estimation error, and $\Gamma_1 = \Gamma_1^T > 0$ is a matrix of adaptation gains.

The time derivative of V_1 along the trajectories of (21) is

$$\begin{aligned} \dot{V}_1 &= z_1 \dot{z}_1 + \tilde{\varphi}^T \Gamma_1^{-1} \dot{\tilde{\varphi}} \\ &= z_1 [\chi(z_2 + \Phi) + v^T \varphi + \psi] + \tilde{\varphi}^T \Gamma_1^{-1} \dot{\tilde{\varphi}} \end{aligned} \quad (23)$$

The virtual control function Φ is chosen as

$$\begin{aligned} \Phi(z_1, \xi, \mathbf{e}, \hat{\rho}, t) &\triangleq -\hat{\rho} \phi(z_1, \xi, \mathbf{e}, \hat{\rho}, t) \\ &= -\hat{\rho} (\kappa_1 z_1 + v^T \hat{\varphi} + \psi), \end{aligned} \quad (24)$$

where $\kappa_1 > 0$ is the controller gain, and $\hat{\rho}$ is the estimate of $\rho = 1/\chi$ that is introduced since the direct estimate $\hat{\chi}$ may occasionally take value zero.

Inserting the virtual control law (24) into (23) the time derivative of the Lyapunov function reads

$$\dot{V}_1 = -\kappa_1 z_1^2 + \chi z_1 z_2 - \chi \tilde{\rho} \phi z_1 - \tilde{\varphi}^T (\Gamma_1^{-1} \dot{\tilde{\varphi}} - v z_1), \quad (25)$$

which is sign undetermined due to the presence of the last three terms. However, instead of designing adaptation laws directly in this step that will allow suppressing the contributions related to $\tilde{\rho}$ and $\tilde{\varphi}$, the next step is awaited and the tuning function $\pi = v z_1$ is introduced. The term $\chi z_1 z_2$ will also be dealt with in the next step.

The z_1 -dynamics with the virtual control law $\Phi(s, \xi, \mathbf{e}, \hat{\rho}, t)$ becomes

$$\dot{z}_1 = -\kappa_1 z_1 + \chi(z_2 - \tilde{\rho} \phi) + v^T \tilde{\varphi}. \quad (26)$$

Step 2 The z_2 -dynamics is given by

$$\begin{aligned} \dot{z}_2 &= \dot{\beta} - \dot{\Phi}(z_1, \xi, \mathbf{e}, \hat{\rho}, t) \\ &= -\frac{1}{\tau_\beta} (\beta - \beta_c) \\ &\quad - \left(\frac{\partial \Phi}{\partial z_1} \dot{z}_1 + \frac{\partial \Phi}{\partial \xi} \dot{\xi} + \frac{\partial \Phi}{\partial \mathbf{e}} \dot{\mathbf{e}} + \frac{\partial \Phi}{\partial \hat{\varphi}} \dot{\hat{\varphi}} + \frac{\partial \Phi}{\partial \hat{\rho}} \dot{\hat{\rho}} + \frac{\partial \Phi}{\partial t} \right) \end{aligned}$$

$$\begin{aligned}
&= -\frac{1}{\tau_\beta} (\beta - \beta_{\text{ref}}) + \hat{\rho} \kappa_1 (\chi \beta + v^T \varphi + \psi) + \hat{\rho} v^T \dot{\hat{\phi}} \\
&\quad + \hat{\rho} \left(\frac{\partial v^T}{\partial \theta_i} \hat{\phi} + \frac{\partial \psi}{\partial \theta_i} \right) - \hat{\rho} \Lambda (\chi \beta + v^T \varphi + \psi - \Lambda \tilde{\omega}_i) \\
&\quad + (\kappa_1 z_1 + v^T \hat{\phi} + \psi) \dot{\hat{\rho}} + \hat{\rho} \left(\sigma^T \hat{\phi} + \frac{\partial \psi}{\partial t} \right) \quad (27)
\end{aligned}$$

where the partial derivatives of the virtual control input $\Phi(z_1, \xi, \mathbf{e}, \hat{\phi}, \hat{\rho}, t)$ are given in the Appendix. As shown in (45) the computation of $\partial v^T / \partial t$ would require the time derivative of the wind speed \dot{U}_∞ . Although the wind speed is available from measurement, its differentiation will produce a very noisy signal that will deteriorate the performance of the control system. Therefore the additional unknown parameter $\sigma^T = \partial v^T / \partial t$ is added and, once again assuming that its variation over time is small (i.e. $\dot{\sigma} \approx 0$), an estimate of it will be computed in the control algorithm.

Consider the control Lyapunov function candidate

$$V_2 = V_1 + \frac{1}{2} z_2^2 + \frac{1}{2\gamma_1} \tilde{\chi}^2 + \frac{|\chi|}{2\gamma_2} \tilde{\rho}^2 + \frac{1}{2} \tilde{\sigma}^T \Gamma_2^{-1} \tilde{\sigma} \quad (28)$$

where $\gamma_1 > 0$, $\gamma_2 > 0$, and $\Gamma_2 > 0$ are adaptation gains. The time derivative of V_2 along the trajectories of the z_2 -dynamics reads

$$\dot{V}_2 = \dot{V}_1 + z_2 \dot{z}_2 + \frac{1}{\gamma_1} \tilde{\chi} \dot{\tilde{\chi}} + \frac{|\chi|}{\gamma_2} \tilde{\rho} \dot{\tilde{\rho}} + \tilde{\sigma}^T \Gamma_2^{-1} \dot{\tilde{\sigma}} \quad (29)$$

Stabilization of the (z_1, z_2) -dynamics is achieved through the collective pitch control law (16) with the parameter estimation laws (17)-(20). Inserting the adaptive control law (16), (17)-(20) into (29) the time derivative of the Lyapunov function reads

$$\begin{aligned}
\dot{V}_2 &= -\kappa_1 z_1^2 - \kappa_2 z_2^2 - \tilde{\chi} \left(\frac{1}{\gamma_1} \dot{\tilde{\chi}} - z_1 z_2 + \frac{\partial \Phi}{\partial z_1} \beta z_2 \right) \\
&\quad - \tilde{\rho} \left(\frac{|\chi|}{\gamma_1} \dot{\tilde{\rho}} + \chi \phi z_1 \right) - \tilde{\sigma}^T (\Gamma_2^{-1} \dot{\tilde{\sigma}} - \hat{\rho} \dot{\hat{\phi}} z_2) \\
&\quad - \tilde{\phi}^T \left[\Gamma^{-1} \dot{\tilde{\phi}} - \pi + \left(\frac{\partial \Phi}{\partial z_1} + \frac{\partial \Phi}{\partial \tilde{\omega}_i} \right) v z_2 \right] \\
&= -\kappa_1 z_1^2 - \kappa_2 z_2^2 \leq 0. \quad (30)
\end{aligned}$$

The LaSalle-Yoshizawa theorem [13, Theorem 2.1] establishes that the error state vector \mathbf{z} and the parameter estimates $\tilde{\chi}$, $\tilde{\rho}$, $\tilde{\sigma}$ are bounded, and $\mathbf{z} \rightarrow 0$ as $t \rightarrow \infty$. Since $z_1 = s$, s is also bounded and converges to zero. This in turn implies that the tracking error dynamics asymptotically is constrained to the manifold $s = 0$, where the $\tilde{\theta}_i$ -dynamics is governed by $\dot{\tilde{\theta}}_i = -\Lambda \tilde{\theta}_i$. Hence $\tilde{\theta}_i \rightarrow 0$ as $t \rightarrow \infty$, that is $\theta_i \rightarrow \theta_{i,\text{ref}}$.

Due to the boundedness of z_2 and the virtual control input $\Phi(z_1, \xi, \mathbf{e}, \hat{\phi}, \hat{\rho}, t)$ also the pitch blade angle β is bounded. From (16) it follows that also the control input β_{ref} is bounded. \square

B. Electrical Power Regulation

The second control objective is the power regulation at the rated value \bar{P}_e . Let $e_P = \bar{P}_e - P_e$ be the power regulation error,

then the control goal can be reformulated as the stabilization of the origin of the power error dynamics

$$\begin{aligned}
\dot{e}_P &= -\dot{P}_e \\
&= -N [\dot{\omega}_r T_g + \omega_r \dot{T}_g] \\
&= -N \left[\dot{\omega}_r T_g - \frac{\omega_r}{\tau_g} (T_g - T_{g,\text{ref}}) \right]. \quad (31)
\end{aligned}$$

Instead of inserting (6) into (31), which will result in an explicit dependency on the complex and uncertain power coefficient $C_P(\lambda, \beta)$, the term $N \dot{\omega}_r T_g$ is considered as a time-varying bounded disturbance $d(t)$. The control objective is then achieved through a PI regulator, which guarantees global uniform ultimate boundedness (GUUB) of the solutions of the closed loop e_P -dynamics. If the disturbance is constant then the power controller guarantees global exponential stability (GES) of the origin of the e_P -dynamics.

Proposition 2. Consider the system

$$\dot{e}_P = N \frac{\omega_r}{\tau_g} T_g - N \frac{\omega_r}{\tau_g} T_{g,\text{ref}} + d \quad (32)$$

where $|d(t)| \leq d_{\max} \forall t > 0$. The PI regulator

$$T_{g,\text{ref}} \triangleq T_g + \frac{\tau_g}{N \omega_r} \left(\kappa_3 e_P + \kappa_4 \int_0^t e_P d\tau \right), \quad \omega_r \neq 0 \quad (33)$$

guarantees that the solutions of the closed loop e_P -dynamics are globally uniformly ultimately bounded. If the disturbance $d(t) = d_0$ then (33) renders the origin of e_P -dynamics globally exponentially stable. The controller gains satisfy $\kappa_3 > \delta > 0$, and $\kappa_4 > 0$.

Proof. The closed loop system augmented with an integral state read as

$$\dot{e}_I = e_P \quad (34)$$

$$\dot{e}_P = -\kappa_3 e_P - \kappa_4 e_I + d \quad (35)$$

Consider the Lyapunov function $W(\eta) = \frac{1}{2} \eta^T \mathbf{P} \eta$ where

$$\mathbf{P} = \begin{bmatrix} \kappa_4 + \delta \kappa_3 & \delta \\ \delta & 1 \end{bmatrix} \quad (36)$$

and $\eta = [e_I, e_P]^T$. $W(\eta)$ is positive definite if $0 < \delta < \kappa_3/2 + \sqrt{\kappa_3^2/4 + \kappa_4}$. The time derivative of $W(\eta)$ along the trajectories of (34)-(35) is

$$\begin{aligned}
\dot{W} &= -(\kappa_3 - \delta) e_P^2 - \delta \kappa_4 e_I + (e_P + \delta e_I) d \\
&\leq -\min\{\kappa_3 - \delta, \delta \kappa_4\} \|\eta\|_2^2 + \sqrt{1 + \delta^2} \|\eta\|_2 d_{\max} \\
&= -(1 - \vartheta) \min\{\kappa_3 - \delta, \delta \kappa_4\} \|\eta\|_2^2 \\
&\quad - \vartheta \min\{\kappa_3 - \delta, \delta \kappa_4\} \|\eta\|_2^2 + \sqrt{1 + \delta^2} \|\eta\|_2 d_{\max} \\
&\leq -(1 - \vartheta) \min\{\kappa_3 - \delta, \delta \kappa_4\} \|\eta\|_2^2 \quad (37)
\end{aligned}$$

$\forall \|\eta\|_2 \geq \frac{\sqrt{1 + \delta^2} d_{\max}}{\vartheta \min\{\kappa_3 - \delta, \delta \kappa_4\}}$ with $0 < \vartheta < 1$. Hence the solutions of (34)-(35) are globally uniformly ultimately bounded.

If $d = d_0$ then by choosing $\kappa_3 > \delta + d_0$ and $\kappa_4 > d_0$ it follows that $\dot{W} \leq -\min\{\kappa_3 - \delta - d_0, \delta(\kappa_4 - d_0)\} \|\eta\|_2^2 < 0$. Since $W(\eta)$ is also radially unbounded, i.e. $\lambda_{\min}(\mathbf{P}) \|\eta\|_2^2 \leq W(\eta) \leq \lambda_{\max}(\mathbf{P}) \|\eta\|_2^2$, then the origin of the power error dynamics is GES [12, Theorem 4.10]. \square

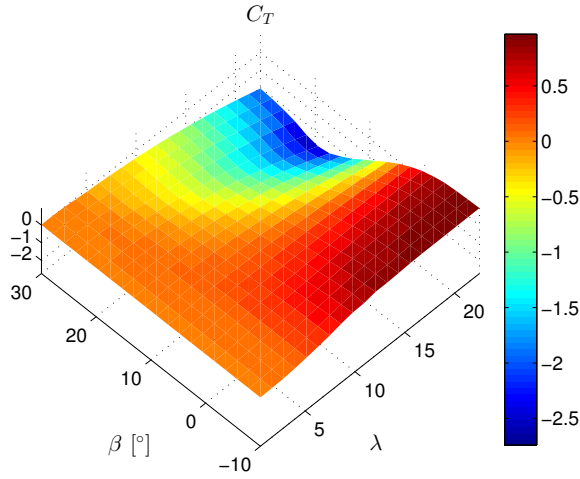

Fig. 2. Thrust coefficient $C_T(\lambda, \beta)$ for NREL 5 MW offshore baseline wind turbine.

IV. PERFORMANCE ASSESSMENT

The tracking and stabilization performance of the proposed adaptive control system architecture has been tested through simulations. The wind turbine model is based on the three-blade, variable speed-variable pitch 5 MW baseline wind turbine described in [11]. The lightweight tower flexibility has been included by treating the wind turbine as an inverted pendulum.

The thrust coefficient, $C_T(\lambda, \beta)$, and power coefficient, $C_P(\lambda, \beta)$, have been calculated in [2] using the blade element momentum theory as described in [7]. Figure 2 shows the obtained thrust coefficient for the considered turbine.

First, deterministic simulations including only step changes in the mean wind speed have been run to assess that the proposed control system is in fact capable of asymptotically tracking reference changes in tower angular displacement while regulating the generated electrical power at the rated value. Then the control system has been tested against a wind gust to assess the capability of withstanding sudden and large wind speed variation. Last, stochastic simulations have been run to evaluate the performance of the control system in more realistic operational wind conditions.

A. Tower Displacement Trajectory Generator

The reference trajectory $\Theta_{\text{ref}} = [\theta_{t,\text{ref}}, \omega_{t,\text{ref}}, \dot{\omega}_{t,\text{ref}}, \ddot{\omega}_{t,\text{ref}}]^T$ for the adaptive collective pitch controller is provided through a fourth order low-pass filter whose input is $\theta_{t,\text{ref}}$. The current reference angle $\theta_{t,\text{ref}}$ is computed by means of (7) as

$$\theta_{t,\text{ref}} = \tan^{-1} \left(\frac{h_1 F_T}{I_t (h_1 m_1 + h_2 m_2)} \right) \quad (38)$$

B. Deterministic simulations

Deterministic simulations have been run with a mean wind speed $U_\infty = 15$ m/s and step changes of amplitude 1.5 m/s. Figures 3-5 show the performance of the designed control systems in response to step changes in the mean wind speed.

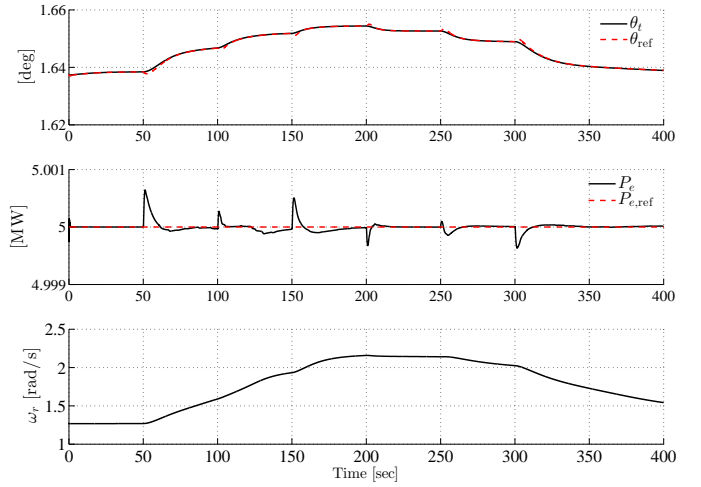

Fig. 3. Control objectives: (top) the tower angular displacement θ_t asymptotically tracks the reference $\theta_{t,\text{ref}}$; (middle) the electrical power P_e is regulated at its nominal value; (bottom) evolution of the uncontrolled rotor angular velocity ω_r .

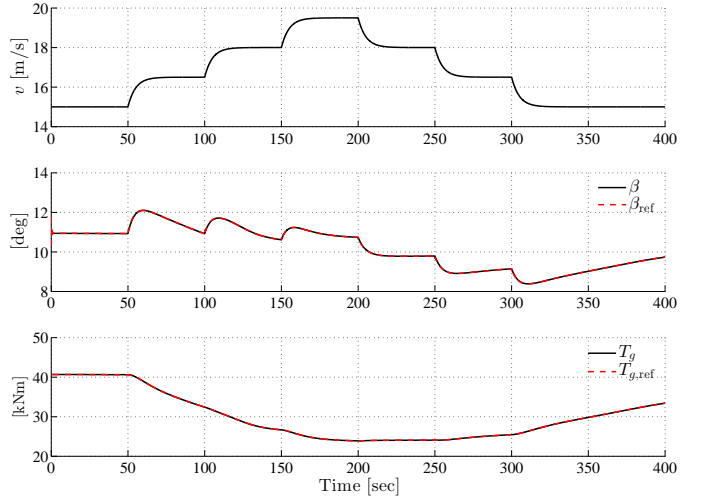

Fig. 4. Control signals: (top) mean wind speed profile; (middle) requested, β_{ref} , and delivered β collective pitch angle; (bottom) requested, $T_{g,\text{ref}}$, and delivered T_g generator torque.

The adaptive backstepping controller asymptotically constrains the dynamics of the tracking error \mathbf{e} on the manifold $s = \tilde{\omega}_t + \Lambda \tilde{\theta}_t$ (Fig. 5). This guarantees that the tower angular displacement θ_t smoothly tracks the reference displacement $\theta_{t,\text{ref}}$, keeping the tower in dynamic balance against the wind. Figure 3 shows an increase of the tower deflection in correspondence of an increase in wind speed. This is clearly expected since the thrust force increases together with the wind speed and hence the tower can lean forward.

The power regulation is easily fulfilled by the designed PI regulator, which after each steps regulates the electrical power back to its nominal value in less than 2 minutes. The control objectives are both achieved without stressing the actuators, which operate away from rate and displacement saturations at all times, as shown in Fig. 4.

Figures 6-7 show the performance of the adaptive closed-

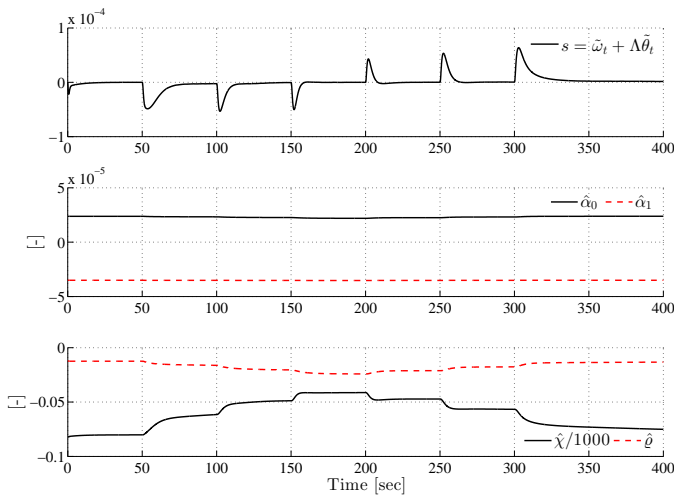

Fig. 5. Control objectives: (top) the adaptive backstepping controller asymptotically constrains the tracking error dynamics on the manifold s ; (bottom) estimates of the parameters α_0 and α_1 .

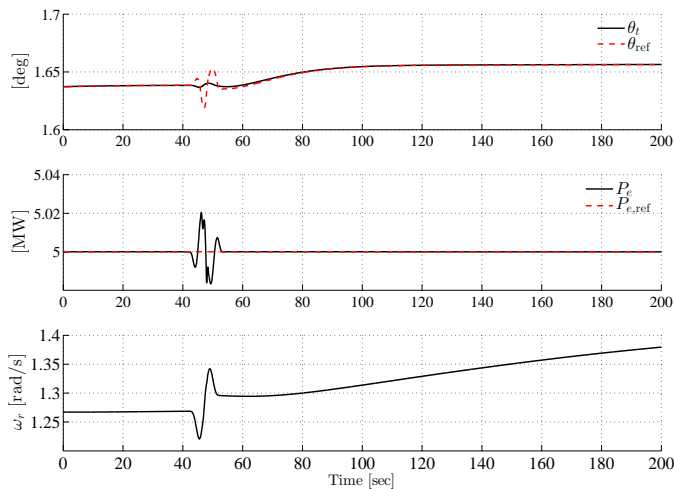

Fig. 6. Control objectives for wind gust: (top) the tower angular displacement θ_t asymptotically tracks the reference $\theta_{t,ref}$; (middle) the electrical power P_e is regulated at its nominal value; (bottom) evolution of the uncontrolled rotor angular velocity ω_r .

loop system in response to an extreme rising wind gust, which has been designed in agreement with the international standard specified in IEC 61400-1: 15 m/s rising wind gust on top of the mean wind speed $U_\infty = 15$ m/s. The adaptive collective pitch controller stabilizes the tower deflection θ_t around its reference trajectory (Fig. 6 (top)), guaranteeing that the moments due to the gravity force and the thrust force are dynamically in balance and without overloading the pitch actuator (Fig. 7 (middle)).

To be noted that although the wind speed goes back to its initial value the system does not converge to the initial operating point. This is a consequence of the fact that the rotor angular velocity ω_r is not controlled, and hence it varies in response to variations in aerodynamic torque T_a and generator torque T_g according to (6). Simulating over a longer period of time it is possible to observe that both ω_r

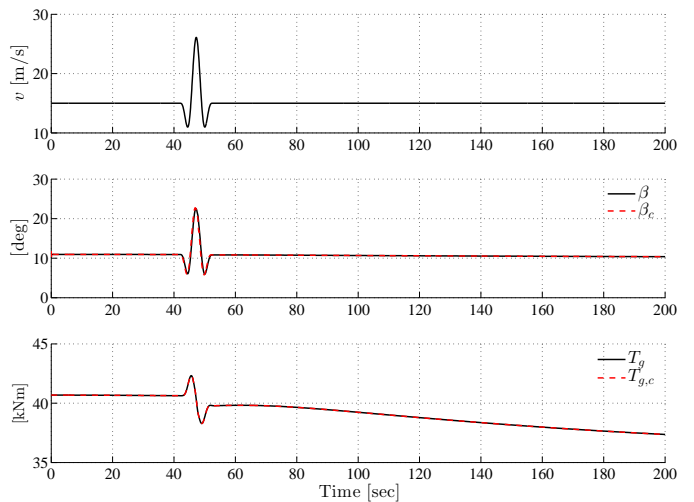

Fig. 7. Control signals for wind gust: (top) wind speed profile with wind gust; (middle) requested, β_{ref} , and delivered β collective pitch angle; (bottom) requested, $T_{g,ref}$, and delivered T_g generator torque.

and T_g reach new steady state values; therefore the dynamics of the whole system remains bounded.

C. Stochastic simulations

Stochastic simulations have been run using the RISØ DTU SB-2 wind model [9] that includes the rotational turbulence and the tower shadow effects. The turbulence intensity is 12%. The wind speed is then computed as an average value of the fixed-point wind speed over the whole rotor. The mean wind speed U_∞ used in the simulations is 15 m/s.

Figures 8-9 show the performance of the proposed control architecture. The wind speed fluctuations introduce continuous variations in the desired tower position $\theta_{t,ref}$; nevertheless the adaptive collective pitch controller well tracks the mean value of the reference trajectory, as shown in Fig. 8 (top), keeping the moment due to the gravity force always in dynamic balance with the moment due to the thrust force.

V. CONCLUSIONS

This paper has investigated the feasibility of advanced nonlinear adaptive control of a wind turbine with a lightweight tower in the full load region. An adaptive backstepping collective pitch controller has been designed to guarantee asymptotic tracking of the reference tower displacement, while a PI regulator has been designed to meet the electrical power generation requirements. Simulation results show the efficacy of the proposed control architecture: the tracking and regulation control objectives are met simultaneously without overloading the actuators.

APPENDIX

The total time derivative of the virtual control input $\Phi(z_1, \xi, \mathbf{e}, \hat{\phi}, \hat{\rho}, t)$ is

$$\dot{\Phi} = \frac{\partial \Phi}{\partial z_1} \dot{z}_1 + \frac{\partial \Phi}{\partial \xi} \dot{\xi} + \frac{\partial \Phi}{\partial \mathbf{e}} \dot{\mathbf{e}} + \frac{\partial \Phi}{\partial \hat{\phi}} \dot{\hat{\phi}} + \frac{\partial \Phi}{\partial \hat{\rho}} \dot{\hat{\rho}} + \frac{\partial \Phi}{\partial t} \quad (39)$$

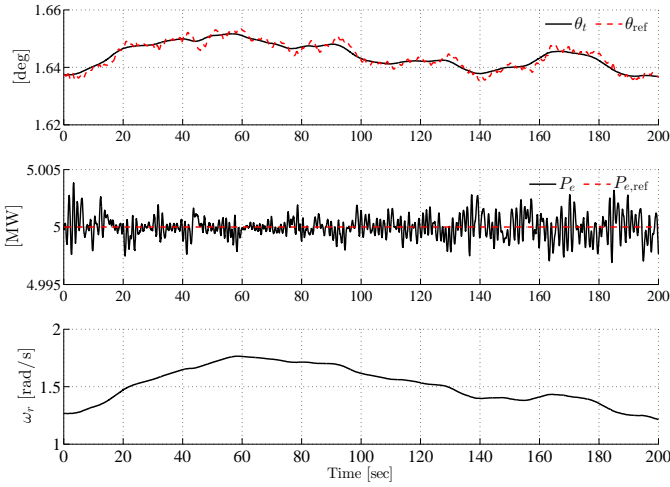

Fig. 8. Control objectives for the stochastic simulation: (top) the tower angular displacement θ_t tracks in mean value the reference $\theta_{t,\text{ref}}$; (middle) the electrical power P_e is well regulated keeping the standard deviation below 1 kW; (bottom) evolution of the uncontrolled rotor angular velocity ω_r .

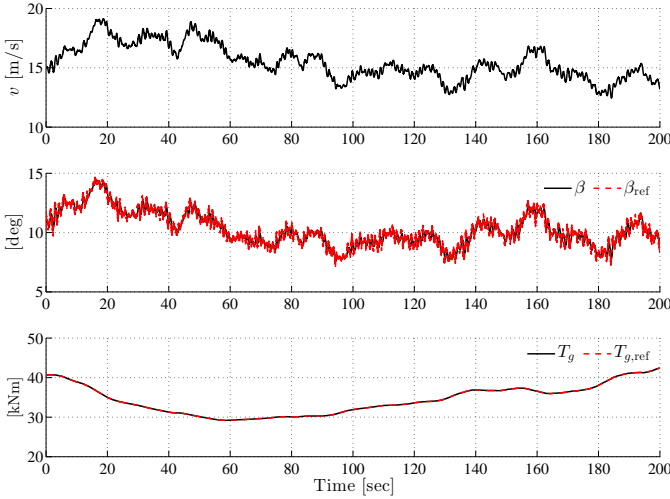

Fig. 9. Control signals for the stochastic simulation: (top) wind speed profile; (middle) requested, β_{ref} , and delivered β collective pitch angle; (bottom) requested, $T_{g,\text{ref}}$, and delivered T_g generator torque.

where the partial derivatives are given by

$$\frac{\partial \Phi}{\partial z_1} = -\hat{\rho} \kappa_1 \quad (40)$$

$$\begin{aligned} \frac{\partial \Phi}{\partial \xi} &= -\hat{\rho} \left[\frac{\partial v^T}{\partial \theta_t} \hat{\phi} + \frac{\partial \psi}{\partial \theta_t}, \frac{\partial v^T}{\partial \omega_t} \hat{\phi} + \frac{\partial \psi}{\partial \omega_t} \right] \\ &= -\hat{\rho} [-U_\infty (\hat{\alpha}_0 U_\infty + \hat{\alpha}_1 \omega_r) \sin \theta_t - c_1 \cos \theta_t, 0] \end{aligned} \quad (41)$$

$$\begin{aligned} \frac{\partial \Phi}{\partial \mathbf{e}} &= -\hat{\rho} \left[\frac{\partial \psi}{\partial \hat{\theta}_t}, \frac{\partial \psi}{\partial \hat{\omega}_t} \right] \\ &= -\hat{\rho} [0, -\Lambda] \end{aligned} \quad (42)$$

$$\frac{\partial \Phi}{\partial \hat{\phi}} = -\hat{\rho} v^T = -\hat{\rho} [U_\infty^2 \cos \theta_t, \omega_r U_\infty \cos \theta_t] \quad (43)$$

$$\frac{\partial \Phi}{\partial \hat{\rho}} = -(\kappa_1 z_1 + v^T \hat{\phi} + \psi)$$

$$\begin{aligned} &= -(\kappa_1 z_1 + \hat{\alpha}_0 U_\infty^2 \cos \theta_t + \hat{\alpha}_1 \omega_r U_\infty \cos \theta_t + \dot{\omega}_{t,\text{ref}} \\ &\quad - c_1 \sin \theta_t - \Lambda \tilde{\omega}_t) \end{aligned} \quad (44)$$

$$\begin{aligned} \frac{\partial \Phi}{\partial t} &= -\hat{\rho} \left(\frac{\partial v^T}{\partial t} \hat{\phi} + \frac{\partial \psi}{\partial t} \right) \\ &= -\hat{\rho} [\dot{\omega}_{t,\text{ref}} + 2\hat{\alpha}_0 U_\infty \dot{U}_\infty \cos \theta_t \\ &\quad + \hat{\alpha}_1 (\dot{\omega}_r U_\infty \cos \theta_t + \omega_r \dot{U}_\infty \cos \theta_t)] \end{aligned} \quad (45)$$

REFERENCES

- [1] F. D. Bianchi, H. De Battista, and R. J. Mantz. *Wind Turbine Control Systems - Principles, Modeling and Gain Scheduling Design*. Springer, 2007.
- [2] K. T. Borup. Modeling and nonlinear control of a 2-dof wind turbine. Master's thesis, The Technical University of Denmark, 2013.
- [3] B. Boukhezzer and H. Siguerdijane. Nonlinear control of a variable-speed wind turbine using a two-mass model. *IEEE Transactions on Energy Conversion*, 26(1):149–162, March 2011.
- [4] T. Burton, N. Jenkins, D. Sharpe, and E. Bossanyi. *Wind Energy Handbook - Second Edition*. John Wiley and Sons, Ltd., 2011.
- [5] R. Galeazzi, M. P. S. Gryning, and M. Blanke. Observer backstepping control for variable speed wind turbine. In *Proceedings of the 2013 American Control Conference*, 2013.
- [6] M. Geyler and P. Caselitz. Robust multivariable pitch control design for load reduction on large wind turbines. *Journal of Solar Energy Engineering*, 130(3), 2008.
- [7] M. O. L. Hansen. *Aerodynamics of Wind Turbines*. Earthscan, 2008.
- [8] L. C. Henriksen. Model predictive control of a wind turbine. Master's thesis, The Technical University of Denmark, 2007.
- [9] F. Iov, A. D. Hansen, P. Sørensen, and F. Blaabjerg. Wind turbine blockset in matlab/simulink. Technical report, Aalborg University, 2004.
- [10] K. E. Johnson and L. J. Fingersh. Adaptive pitch control of variable-speed wind turbines. *Journal of Solar Energy Engineering*, 130(3), 2008.
- [11] J. Jonkman, S. Butterfield, W. Musial, and G. Scott. Definition of a 5-MW reference wind turbine for offshore system development. Technical Report NREL/TP-500-38060, National Renewable Energy Laboratory, February 2009.
- [12] H. K. Khalil. *Nonlinear Systems - Third Edition*. Pearson Education International Inc., 2001.
- [13] M. Krstic, I. Kanellakopoulos, and P. Kokotovic. *Nonlinear And Adaptive Control Design*. John Wiley and Sons, Inc., 1995.
- [14] J.H. Laks, L. Y. Pao, and A. D. Wright. Control of wind turbines: Past, present, and future. In *Proceedings of the 2009 American Control Conference*, pages 2096–2103, 2009.
- [15] W.E. Leithead and B. Connor. Control of variable speed wind turbines: Design task. *International Journal of Control*, 73(13):1189–1212, 2000.
- [16] M. Mirzaei, H. H. Niemann, and N. K. Poulsen. A μ -synthesis approach to robust control of a wind turbine. In *Proceedings of the 50th IEEE Conference on Decision and Control and European Control Conference*, 2011.
- [17] K. Z. Østergaard. *Robust, Gain-Scheduled Control of Wind Turbines*. PhD thesis, Aalborg University, 2008.
- [18] S. Raach, D. Schlipf, F. Sandner, D. Matha, and P. W. Cheng. Nonlinear model predictive control of floating wind turbines with individual pitch control. In *Proceedings of 2014 American Control Conference*, pages 4434–4439, 2014.
- [19] Y.D. Song, B. Dhinakaran, and X.Y. Bao. Variable speed control of wind turbines using nonlinear and adaptive algorithms. *Journal of Wind Engineering and Industrial Aerodynamics*, 85:293–308, 2000.
- [20] K. L. Sørensen, R. Galeazzi, P. F. Odgaard, H. H. Niemann, and N. K. Poulsen. Adaptive passivity based individual pitch control for wind turbines in the full load region. In *Proceedings of the 2014 American Control Conference*, 2014.
- [21] S. Tegen, E. Lantz, M. Hand, B. Maples, A. Smith, and P. Schwabe. 2011 cost of wind energy review. Technical Report NREL/TP-5000-56266, National Renewable Energy Laboratory, 2013.
- [22] G.J. van der Veen, I. J. Couchman, and R.O Bowyer. Control of floating wind turbines. In *Proceedings of the 2012 American Control Conference*, pages 3148–3153, 2012.